



250008343110



中国认可
国际互认
检测
TESTING
CNAS L0681

CHPTL

CERTIFICATE OF TESTS

No : CTQC/B-25. 0435

Entrusted by: Qingdao Cahors Electrical Equipment Co., Ltd.

Manufacturer: Qingdao Cahors Electrical Equipment Co., Ltd.

Test object name: 3 phase transformer

Test object type: 2000kVA 22.6/0.395kV

Serial No.: 287250002C

Test items: Routine tests, type tests, measurement of the harmonics of the no-load current, measurement of zero-sequence impedance on three-phase transformers, short-circuit withstand test, induced voltage test with partial discharge measurement.

Standards: IEC60076-1: 2011, IEC60076-2: 2011, IEC60076-3: 2013, IEC60076-5: 2006, technical contract.

Results: The test results of routine tests, type tests, measurement of the harmonics of the no-load current, measurement of zero-sequence impedance on three-phase transformers, short-circuit withstand test, induced voltage test with partial discharge measurement of 2000kVA 22.6/0.395kV are in accordance with standards and technical contract requirements. The sample passed the above tests.

Approved: Lv Xiangpeng

Handwritten signature and date: 2026.2.10



SHENYANG TRANSFORMER RESEARCH INSTITUTE CO., LTD.

CHINA NATIONAL TRANSFORMER QUALITY INSPECTION AND TESTING CENTER



250008343110



中国认可
国际互认
检测
TESTING
CNAS L0681



CHPTL

TYPE TEST REPORT

No : CTQC/B-25. 0435

Test object name: 3 phase transformer

Test object type: 2000kVA 22.6/0.395kV

Entrusted by: Qingdao Cahors Electrical Equipment
Co., Ltd.

Manufacturer: Qingdao Cahors Electrical Equipment
Co., Ltd.

Kind of testing: Type tests

SHENYANG TRANSFORMER RESEARCH INSTITUTE CO., LTD.

CHINA NATIONAL TRANSFORMER QUALITY INSPECTION AND TESTING CENTER



CX-F-01	Test Report	No: CTQC/B-25.0435 Total 38 Page 1
---------	-------------	---------------------------------------

CONTENTS

	Page
1. Certificate of type tests	
2. Type test report cover	
3. Contents.....	1
4. Signing and issuing.....	2
5. Test results.....	3~5
6. Test object parameters.....	6
7. Sample condition description.....	6
8. Standards.....	6
9. Test items and conclusions.....	7~38
10. Annex 1: Rating plate and outline photos(Total page 1)	
11. Annex 2: Test circuits(Total pages 8)	
12. Annex 3: Transformer drawings(Total pages 2)	



Shenyang Transformer Research Institute Co., Ltd.

China National Transformer Quality Inspection And Testing Center

Type Test Report

No: CTQC/B-25. 0435

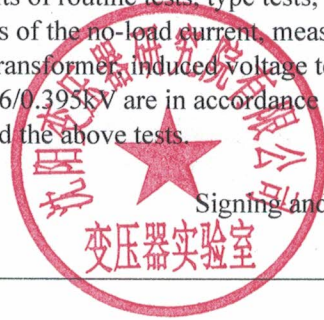
Total 38 Page 2

Test object name	3 phase transformer	Test object type	2000kVA 22.6/0.395kV
		Brand	/
Entrusted by	Qingdao Cahors Electrical Equipment Co., Ltd.	Kind of testing	Type tests
Manufacturer	Qingdao Cahors Electrical Equipment Co., Ltd. 	Sampling date	Dec. 11, 2025
		Test date	Jan. 12, 2026~Jan. 20, 2026
Address	197 Pingshan Road, Qingdao E&T Dept Zone, 266500, Qingdao, Shandong, China	Serial No.	287250002C
Standards	IEC60076-1: 2011 IEC60076-2: 2011 IEC60076-3: 2013 IEC60076-5: 2006 Technical contract	Test items	Routine test Type test Short-circuit withstand test Measurement of the harmonics of the no-load current Measurement of zero sequence impedance of three-phase transformer Induced voltage test with partial discharge measurement
Result	The test results of routine tests, type tests, short-circuit withstand test, measurement of the harmonics of the no-load current, measurement of zero sequence impedance of three-phase transformer, induced voltage test with partial discharge measurement of 2000kVA 22.6/0.395kV are in accordance with standards and technical contract. The sample passed the above tests.		
Note	Signing and issuing date:  2026.02.10 		

Approved by: Lv Xiangpeng

Checked by: Dou Zhitao

Compiled by: Jiang Anping

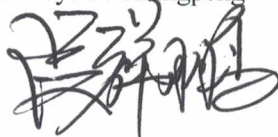
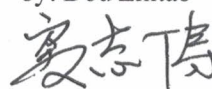
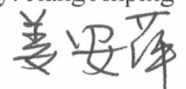
- Statement:
1. Testing report is invalid without test special seal.
 2. Testing report is invalid without compiler, checker and approver's signature.
 3. Please inform CTQC in time after received the testing report if you have some disagreement to the testing report.
 4. Testing or witnessing only apply to sample.
 5. Copying testing certificate or testing report is forbidden without written permission from CTQC(except for copying all the testing report).

Test Report				№: CTQC/B-25.0435 Total 38 Page 3	
Test results					
№	Test items	Specified values	Measured values		Conclusions
		Standards(Technical contract)	Before S.C.T	After S.C.T	
1	Measurement of d.c. insulation resistance each winding to earth and between windings (Routine test)	Providing resistance value(GΩ)	H-L.E: 2.36 L-H.E: 1.53 H.L-E: 1.36 H-L: 3.35	H-L.E: 3.70 L-H.E: 2.57 H.L-E: 1.58 H-L: 3.75	/
2	Measurement of voltage ratio and check of phase displacement (Routine test)	The tolerances of voltage ratio on principal tapping: $\pm 0.5\%$ Connection symbol: Dyn11	-0.08% Dyn11	0.09~0.10% Dyn11	Passed
3	Measurement of winding resistance (Routine test)	Providing winding resistance value	See 4.3	See 4.16.3.3	/
4	Measurement of no-load loss and current (Routine test)	I ₀ ‰: Providing measured values P ₀ (kW): ≤ 1.32	0.09 1.27	0.09 1.27	/
5	Measurement of short-circuit impedance and load loss (Routine test)	t: 75°C Z%: 7.90%~9.23%(Tap1) Z%: 7.82%~9.14%(Tap2) Z%: 7.75%~9.05%(Tap3) Z%: 7.67%~8.96%(Tap4) Z%: 7.60%~8.87%(Tap5) Tap 5 P _k (kW): ≤ 13.5 P _{Total} (kW): ≤ 14.82	8.86 8.66 8.50 8.30 8.10 12.39 13.66	8.89 8.69 8.53 8.32 8.13 12.58 13.85	Passed
6	Test on dielectric liquid (Routine test)	Breakdown voltage(kV): ≥ 55 Water dissolved(mg/L): ≤ 200	68.4 30	65.9 30	Passed
		Providing gas chromatography	Gas chromatography		
7	Lightning impulse test (Type test)	Full Wave(kV): 125 $\pm 3\%$ Cropped Wave(kV): 138 $\pm 3\%$	See 4.7	See 4.16.3.7	Passed
8	Applied voltage test (Routine test)	HV: 50kV 60s LV: 6kV 60s	50kV 60s 6kV 60s	50kV 60s 6kV 60s	Passed
9	Auxiliary wiring insulation test (AuxW) (Routine test)	Auxiliary wiring: 2kV 60s	2kV 60s	2kV 60s	Passed

Test Report				№: CTQC/B-25.0435 Total 38 Page 4	
№	Test items	Specified values	Measured values		Conclusions
		Standards(Technical contract)	Before S.C.T	After S.C.T	
10	Induced voltage withstand test (Routine test)	Applied voltage(kV): $2U_r$ Induced voltage(kV): 45.2 Duration(s): $120(f_r/f)$ Frequency(Hz): $f > 50$	0.790 45.2 40 150	0.790 45.2 40 150	Passed
11	Tightness tests (Routine test)	Applied pressure(kPa): 20 Residual pressure(kPa): ≥ 14 Duration(h): 24 No oil leakage and damage	20 20 24 No oil leakage and damage		Passed
12	Measurement of no-load loss and current at 90% and 110% of rated voltage (Type test)	$I_0\%$: Providing measured values P_0 (kW): Providing measured values	90% 0.06 0.99	110% 0.17 1.60	/
13	Measurement of the harmonics of the no-load current (Special test)	Providing no-load current harmonic values	See 4.13		/
14	Determination of sound level (Type test)	Sound pressure level $\overline{L_{PA}}$ dB(A): ≤ 53 Sound power level $L_{WA,SN}$ dB(A): ≤ 63	42 55		Passed
15	Temperature rise test (Type test)	Top oil temp.-rise limit(K): 45 Winding temp.-rise limit(K): 50	Top oil: 43.4 HV: 43.1 LV: 44.1		Passed
16	Short-circuit withstand test (Special test)	Three times each phase Duration(s): $1.0 \pm 10\%$ Test waveforms have no distortion Deviation of reactance before and after S.C.T.: $\pm 4.0\%$ No obvious changes observed in the core lifting inspection Successfully check items after S.C.T.	3 times 1.0 No distortion 0.29% No apparent defects Passed		Passed
17	Measurement of zero-sequence impedance on three phase transformers (Special test)	Providing zero-sequence impedance value(Ω)	0.006843		/

Test Report		№: CTQC/B-25.0435 Total 38 Page 5		
№	Test items	Specified values	Measured values	Conclusions
		Standards(Technical contract)		
18	Induced voltage test with partial discharge measurement (IVPD) (Special test)	U ₁ =2.0U _r /√3 (kV) Duration(s): 120(f _n /f)	26.10 40	Passed
		U ₂ =1.58U _r /√3 (kV) Duration(min): 5 Partial discharge(pC): <50	20.62 5 <10	
		1.2U _r /√3 (kV) Duration(min): 1 Partial discharge(pC): <50	15.66 1 <10	
		0.4U _r /√3 (kV) Duration(min): / Partial discharge(pC): <50	5.22 / <10	
		Frequency(Hz): >50	150	

Test Report					No: CTQC/B-25.0435 Total 38 Page 7			
4. Test items and conclusions								
4.1 Measurement of d.c.insulation resistance each winding to earth and between windings (Routine test)								
Test date: Jan. 12, 2026 Humidity: 15.5%; Oil temperature: 12.1°C; Atmospheric pressure: 100.4kPa								
Measured position				Insulation resistance(GΩ)				
HV-LV&E				2.36				
LV-HV&E				1.53				
HV&LV-E				1.36				
HV-LV				3.35				
4.2 Measurement of voltage ratio and check of phase displacement(Routine test)								
Test date: Jan. 12, 2026 Oil temperature: 12.1°C								
HV winding		LV winding		Ratio	Measured deviation(%)			Connection symbol
Tap position	Voltage (kV)	Tap position	Voltage (kV)		AB/ab	BC/bc	CA/ca	
1	22.6	/	0.380	59.474	0.04	0.04	0.04	Dyn11
2			0.384	59.008	-0.13	-0.14	-0.14	
3			0.388	58.398	-0.08	-0.08	-0.08	
4			0.391	57.801	-0.04	-0.05	-0.05	
5			0.395	57.215	-0.03	-0.04	-0.03	
Result: Passed.								
4.3 Measurement of winding resistance(Routine test)								
Test date: Jan. 12, 2026 Oil temperature: 12.1°C								
Winding	Tap position	DC resistance(Ω)						
		A~B	B~C	C~A				
HV	1	0.8398	0.8402	0.8377				
	2	0.8315	0.8318	0.8294				
	3	0.8231	0.8234	0.8210				
	4	0.8147	0.8150	0.8126				
	5	0.8062	0.8066	0.8042				
LV	/	a~b	b~c	c~a				
		0.0002950	0.0002909	0.0003067				

Test Report						No: CTQC/B-25. 0435 Total 38 Page 8			
4.4 Measurement of no-load loss and current (Routine test) Test circuit is given in Annex 2-a						Test date: Jan. 12, 2026 Oil temperature: 12.1°C			
Multiple	Phase voltage(kV)		No-load current		No-load loss(kW)				
	Mean value	R.M.S.	(A)	(%)	Measured value	Corrected value			
100%U _r	0.228	0.229	2.58	0.09	1.28	1.27			
Result: Passed.									
4.5 Measurement of short-circuit impedance and load loss (Routine test) Test circuit is given in Annex 2-b						Test date: Jan. 13, 2026			
Winding	Tap position	Applied current		Measured voltage (kV)	Short-circuit impedance (Each phase)		Load loss (kW)		Total losses (kW)
					(Ω)	(%)	Measured value	Corrected value	Corrected value
		I (A)	I/I _r (%)		t=75°C	t=75°C I=I _r	t=11.2°C	t=75°C I=I _r	t=75°C I=I _r
HV LV	1	32.16	62.95	1.260	22.63	8.86	4.91	13.27	14.54
	2	32.71	64.02	1.253	22.12	8.66	4.99	13.03	14.30
	3	32.56	63.73	1.224	21.71	8.50	4.88	12.86	14.13
	4	33.27	65.12	1.221	21.20	8.30	4.99	12.61	13.88
	5	33.31	65.20	1.193	20.69	8.10	4.91	12.39	13.66
Result: Passed.									
4.6 Test on dielectric liquid (Routine test)						Test date: Jan. 12, 2026 Humidity: 21.2%; Ambient temperature: 20.5°C			
Breakdown voltage(kV)			Water dissolved(mg/L)			Result			
68.4			30			Passed			
Gas chromatography (Before routine tests)						Test date: Jan. 12, 2026 μL/L			
H ₂	CO	CO ₂	CH ₄	C ₂ H ₆	C ₂ H ₄	C ₂ H ₂	ΣCH		
187.41	7.07	121.54	0.92	21.22	0.39	0.00	22.53		

Test Report						No: CTQC/B-25.0435 Total 38 Page 9		
Gas chromatography(After S.C.T)						Test date: Jan. 18, 2026 μL/L		
H ₂	CO	CO ₂	CH ₄	C ₂ H ₆	C ₂ H ₄	C ₂ H ₂	ΣCH	
195.05	7.82	116.62	0.95	27.31	0.42	0.00	28.68	
4.7 Lightning impulse test (Typical test) The tests were performed after the short-circuit withstand test, see 4.16.3.7								
4.8 Applied voltage test (Routine test)						Test date: Jan. 12, 2026		
Test circuit is given in Annex 2-c Humidity: 15.5%; Oil temperature: 12.1°C; Atmospheric pressure: 100.4kPa								
Measured position		Applied voltage(kV)		Duration(s)		Result		
HV-LV&E		50		60		Passed		
LV-HV&E		6		60				
Auxiliary circuit		2		60				
4.9 Auxiliary wiring insulation test (AuxW) (Routine test) See 4.8								
4.10 Induced voltage withstand test (Routine test)						Test date: Jan. 13, 2026		
Test circuit is given in Annex 2-d Humidity: 22.3%; Oil temperature: 11.2°C; Atmospheric pressure: 101.1kPa								
Tap position	Applied voltage(kV)		Induced voltage(kV)		Induced multiple	Frequency (Hz)	Duration (s)	Result
	LV		HV					
5	0.79		45.2		2	150	40	Passed
4.11 Tightness test (Routine test)						Test date: Jan. 20, 2026 Ambient temperature: 10.5°C		
Test method		Applied pressure (kPa)		Duration (h)		Residual pressure (kPa)		Result
Atmosphere pressure method		20		24		20		No leakage oil and damage, passed.
4.12 Measurement of no-load loss and current at 90% and 110% of rated voltage (Type test) Test date: Jan. 12, 2026 Oil temperature: 12.1°C								
Multiple	Applied voltage(kV)		No-load current		No-load loss(kW)			
	Mean value	R.M.S.	(A)	(%)	Measured value	Corrected value		
90%U _r	0.205	0.206	1.80	0.06	0.995	0.990		
110%U _r	0.251	0.253	4.87	0.17	1.61	1.60		

Test Report

No: CTQC/B-25.0435

Total 38 Page 10

4.13 Measurement of the harmonics of the no-load current (Special test) Test date: Jan. 12, 2026

Test circuit is given in Annex 2-e

Oil temperature: 12.1°C

Or.	U1 [V]	hdf[%]	I1 [A]	hdf[%]
Tot.	228.71		2.7907	
dc				
1	228.67	100.000	2.5178	100.000
2	0.13	0.057	0.1135	4.508
3	0.73	0.319	0.2800	11.120
4	0.12	0.053	0.0528	2.098
5	2.85	1.247	1.0645	42.278
6	0.03	0.013	0.0052	0.206
7	1.04	0.457	0.2841	11.285
8	0.07	0.030	0.0094	0.373
9	0.42	0.182	0.0838	3.329
10	0.07	0.030	0.0150	0.595
11	2.35	1.028	0.3437	13.649
12	0.12	0.052	0.0207	0.822
13	0.24	0.105	0.0712	2.827
14	0.04	0.016	0.0074	0.295
15	0.20	0.087	0.0430	1.708
16	0.05	0.024	0.0127	0.506
17	0.18	0.078	0.0425	1.688
18	0.06	0.026	0.0142	0.563
19	0.29	0.129	0.0763	3.031
20	0.01	0.002	0.0007	0.026

Or.	U2 [V]	hdf[%]	I2 [A]	hdf[%]
Tot.	230.02		2.0285	
dc				
1	229.98	100.000	1.6155	100.000
2	0.15	0.064	0.1216	7.525
3	1.07	0.467	0.4712	29.168
4	0.08	0.036	0.0654	4.048
5	3.12	1.356	1.0408	64.429
6	0.09	0.039	0.0014	0.090
7	0.94	0.410	0.3037	18.801
8	0.08	0.036	0.0142	0.878
9	0.18	0.080	0.0304	1.884
10	0.08	0.033	0.0126	0.781
11	1.62	0.703	0.2330	14.423
12	0.06	0.025	0.0121	0.750
13	0.64	0.279	0.1417	8.774
14	0.04	0.017	0.0069	0.427
15	0.44	0.192	0.0932	5.767
16	0.07	0.029	0.0141	0.871
17	0.21	0.091	0.0534	3.303
18	0.03	0.012	0.0068	0.422
19	0.11	0.047	0.0213	1.316
20	0.01	0.005	0.0025	0.154

Or.	U3 [V]	hdf[%]	I3 [A]	hdf[%]
Tot.	228.03		2.9173	
dc				
1	228.00	100.000	2.6182	100.000
2	0.07	0.031	0.1253	4.785
3	0.41	0.178	0.4666	17.822
4	0.09	0.038	0.0546	2.085
5	2.86	1.256	1.1183	42.712
6	0.06	0.028	0.0054	0.208
7	1.12	0.490	0.3251	12.418
8	0.01	0.006	0.0072	0.273
9	0.24	0.104	0.0616	2.354
10	0.07	0.032	0.0029	0.113
11	1.25	0.547	0.1648	6.295
12	0.06	0.025	0.0089	0.340
13	0.55	0.240	0.1235	4.717
14	0.02	0.011	0.0017	0.064
15	0.37	0.163	0.0812	3.100
16	0.04	0.017	0.0095	0.361
17	0.31	0.136	0.0799	3.053
18	0.03	0.013	0.0079	0.303
19	0.20	0.089	0.0587	2.242
20	0.01	0.006	0.0026	0.101

Test Report				No: CTQC/B-25.0435 Total 38 Page 11	
4.14 Determination of sound level (Type test)				Test date: Jan. 19, 2026	
4.14.1 Sound power level calculation under on load current					
Calculation equation:					
$L_{WA,IN} \approx 39 + 18 \lg \frac{S_r}{S_p} = 44 \text{dB(A)}$					
In which: S_r -Rated power 2.0MVA;					
S_p -Reference power 1MVA.					
$L_{WA,IN}$ is found to be 19dB(A) below the guaranteed sound power level 63dB(A), according to standard, load current sound measurements are not appropriate.					
4.14.2 Determination of sound level for transformer inside the enclosure					
Transformer was energized at rated voltage. The outline was 0.3m away from the principal radiating surface, there were 14 measured points, the measured point interval was 0.69m, the height of oil tank was 1.60m, the height of measured points was 0.80m.					
Environmental conditions				Oil temperature: 10.2°C	
Area of the surface of the test room $S_v(\text{m}^2)$	Mean sound absorption coefficient α	Sound Absorption $A(\text{m}^2)$	Distance from the reference transmitting surface (m)	Area of effective surface $S(\text{m}^2)$	Environmental correction factor K dB(A)
2300	0.2	460	0.3	18.43	0.6
Test results					dB(A)
Cooling method	The average noise level of background		The average noise level of transformer $\overline{L_{PAO}}$	A-weighted surface sound pressure level $\overline{L_{PA}} = 10 \lg(10^{0.1\overline{L_{PAO}}} - 10^{0.1\overline{L_{bgA}}}) - K$	A-weighted sound power level $\overline{L_{WA,UN}} = \overline{L_{PA}} + 10 \lg(S/S_0)$
	Before	After			
ONAN	33.6	34.0	42.7	42	55
<p>Note: $\overline{L_{PAO}}$: Uncorrected average A-weighted sound pressure level; $\overline{L_{PAO}} = 10 \lg\left(\frac{1}{N} \sum_{i=1}^N 10^{0.1L_{PAi}}\right)$</p> <p>$\overline{L_{bgA}}$: The lower of the two calculated average A-weighted background sound pressure level.</p> <p>Result: Passed.</p>					

Test Report		No: CTQC/B-25.0435 Total 38 Page 12
4.15 Temperature rise test (Type test)		Test date: Jan. 14, 2026
The test was conducted by means of short-circuit method. Tap position: HV 5. The test duration was 11.5h, stability duration was 3h.		
Measuring top oil temperature rise: The specified total losses was 13.66kW, injected total losses of 13.28kW during the test.		
Measuring winding temperature rise: Specified current was 51.09 A, injected current of 52.92A during the test.		
Conclusions of temperature rise		Ambient temperature: 11.3°C
Top oil temperature rise(K)	43.4	
Winding temperature rise(K)	HV	43.1
	LV	44.1
Note: The results of temperature rise were corrected value at specified total losses and current. Result: Passed.		

Test Report

No: CTQC/B-25. 0435

Total 38 Page 13

Legend: Data to be inserted

Time interval	$\Delta t =$	1 min					
Initial average liquid temp.	$\theta_{om_start} =$	45.2 °C	Estimated winding time constant	$T_w =$ 27.24 min			
Final average-liquid temp.	$\theta_{om_end} =$	44.0 °C	Estimated average liquid temp.	$A_o =$ 42.93 °C			
Liquid temperature slope	$k =$	0.06 K/min	Estimated winding to liquid temp.	$B =$ 11.16 K			
Auxiliary variables:	Average winding temp. at the instant of shut down			$\theta_{wo} =$ 54.1 °C			
$t_c =$ -1.6057							
$t_e =$ 0.0374							
	Abs Sums:	n	sa	sb	sc	sd	se
		18	5.02	906.94	254.07	45732.11	12.02

Time (min)	R(i) (Ω) × 10 ⁻¹	$\theta_{om}(i) = A_o - kt$	$\theta_{wm}(i)$ as measured	$\theta_{wval}(i)$	$\theta_{wcor}(i)$	$u\{ _ (0/1) \}$	$\theta_w(i)$ as corrected and validated	$\Delta\theta_w(i)$ as per eq. (C.5)	$\theta_w(i) \times \Delta\theta_w(i)$	$(\theta_w(i))^2$	e^{-i/T_w}	$\theta_w(i)$ as calculated
0		42.93										54.10
1		42.87										53.63
2	9.407	42.81	53.18	53.18	53.30	1						53.19
3	9.392	42.75	52.72	52.72	52.90	1	52.90	-0.400	-21.14	2798.59	0.8957	52.75
4	9.378	42.69	52.29	52.29	52.53	1	52.53	-0.369	-19.38	2759.70	0.8634	52.33
5	9.365	42.63	51.89	51.89	52.19	1	52.19	-0.338	-17.65	2724.27	0.8323	51.92
6	9.352	42.57	51.50	51.50	51.86	1	51.86	-0.338	-17.54	2689.08	0.8023	51.53
7	9.340	42.51	51.13	51.13	51.55	1	51.55	-0.308	-15.86	2657.27	0.7734	51.15
8	9.328	42.45	50.76	50.76	51.24	1	51.24	-0.308	-15.76	2625.65	0.7455	50.78
9	9.317	42.39	50.42	50.42	50.96	1	50.96	-0.277	-14.12	2597.34	0.7186	50.42
10	9.306	42.33	50.09	50.09	50.69	1	50.69	-0.277	-14.04	2569.18	0.6927	50.07
11	9.295	42.27	49.75	49.75	50.41	1	50.41	-0.277	-13.96	2541.18	0.6677	49.73
12	9.284	42.21	49.41	49.41	50.13	1	50.13	-0.277	-13.89	2513.33	0.6436	49.40
13	9.274	42.15	49.11	49.11	49.89	1	49.89	-0.246	-12.29	2488.69	0.6204	49.08
14	9.264	42.09	48.80	48.80	49.64	1	49.64	-0.246	-12.23	2464.17	0.5981	48.77
15	9.254	42.03	48.49	48.49	49.39	1	49.39	-0.246	-12.17	2439.78	0.5765	48.47
16	9.244	41.97	48.19	48.19	49.15	1	49.15	-0.246	-12.11	2415.50	0.5557	48.18
17	9.235	41.91	47.91	47.91	48.93	1	48.93	-0.216	-10.56	2394.34	0.5357	47.89
18	9.225	41.85	47.61	47.61	48.69	1	48.69	-0.246	-11.99	2370.30	0.5164	47.62
19	9.217	41.79	47.36	47.36	48.50	1	48.50	-0.185	-8.98	2352.31	0.4978	47.35
20	9.208	41.73	47.08	47.08	48.28	1	48.28	-0.216	-10.42	2331.43	0.4798	47.09
21												
22												
23												
24												
25												
26												
27												
28												
29												
30												

H.V. Winding temp.-rise (K): $\Delta\theta_{WH} = (\theta_{wo} - \theta_{om_star}) \times \left(\frac{I_{rated}}{I_{start}} \right)^y + \Delta\theta_{om} = (54.1 - 45.2) \times \left(\frac{51.09}{52.92} \right)^{1.6} + 34.7 = 43.1$

Test Report	№: CTQC/B-25. 0435 Total 38 Page 14
-------------	----------------------------------------

Legend: Data to be inserted

Time interval	$\Delta t =$	1 min		
Initial average liquid temp.	$\theta_{om_start} =$	45.2 °C	Estimated winding time constant	$T_w =$ 8.14 min
Final average-liquid temp.	$\theta_{om_end} =$	44.0 °C	Estimated average liquid temp.	$A_o =$ 45.91 °C
Liquid temperature slope	$k =$	0.06 K/min	Estimated winding to liquid temp.	$B =$ 9.18 K
Auxiliary variables:	Average winding temp. at the instant of shut down			$\theta_{wo} =$ 55.1 °C

$t_c =$ -6.0007	n	18	s_a	6.40	s_b	875.36	s_c	316.85	s_d	42614.93	s_e	5.33
$t_e =$ 0.1307	Abs Sums:											

Time (min)	R(i) (Ω) × 10 ⁻⁴	$\theta_{om}(i) = A_o - kt$	$\theta_{wm}(i)$ as measured	$\theta_{wval}(i)$	$\theta_{wcor}(i)$	$u\{_{(0/1)}$	$\theta_w(i)$ as corrected and validated	$\Delta\theta_w(i)$ as per eq. (C.5)	$\theta_w(i) \times \Delta\theta_w(i)$	$(\theta_w(i))^2$	e^{-i/T_w}	$\theta_w(i)$ as calculated
0		45.91										55.10
1		45.85										53.97
2	3.389	45.79	52.87	52.87	52.99	1						52.98
3	3.376	45.73	51.77	51.77	51.95	1	51.95	-1.044	-54.25	2698.65	0.6918	52.08
4	3.367	45.67	51.00	51.00	51.24	1	51.24	-0.704	-36.10	2625.95	0.6118	51.29
5	3.360	45.61	50.41	50.41	50.71	1	50.71	-0.535	-27.11	2571.45	0.5411	50.58
6	3.353	45.55	49.81	49.81	50.17	1	50.17	-0.535	-26.82	2517.51	0.4785	49.95
7	3.347	45.49	49.31	49.31	49.73	1	49.73	-0.450	-22.36	2472.59	0.4232	49.38
8	3.342	45.43	48.88	48.88	49.36	1	49.36	-0.365	-18.00	2436.45	0.3743	48.87
9	3.338	45.37	48.54	48.54	49.08	1	49.08	-0.280	-13.73	2408.91	0.3310	48.41
10	3.334	45.31	48.20	48.20	48.80	1	48.80	-0.280	-13.65	2381.53	0.2928	48.00
11	3.330	45.25	47.86	47.86	48.52	1	48.52	-0.280	-13.57	2354.30	0.2589	47.63
12	3.326	45.19	47.52	47.52	48.24	1	48.24	-0.280	-13.50	2327.23	0.2290	47.30
13	3.322	45.13	47.18	47.18	47.96	1	47.96	-0.280	-13.42	2300.31	0.2025	46.99
14	3.318	45.07	46.84	46.84	47.68	1	47.68	-0.280	-13.34	2273.55	0.1791	46.72
15	3.315	45.01	46.59	46.59	47.49	1	47.49	-0.195	-9.25	2255.01	0.1584	46.47
16	3.311	44.95	46.25	46.25	47.21	1	47.21	-0.280	-13.21	2228.52	0.1401	46.24
17	3.308	44.89	45.99	45.99	47.01	1	47.01	-0.195	-9.16	2210.16	0.1239	46.03
18	3.306	44.83	45.82	45.82	46.90	1	46.90	-0.110	-5.15	2199.84	0.1096	45.84
19	3.303	44.77	45.57	45.57	46.71	1	46.71	-0.195	-9.10	2181.60	0.0969	45.66
20	3.301	44.71	45.40	45.40	46.60	1	46.60	-0.110	-5.12	2171.35	0.0857	45.50
21												
22												
23												
24												
25												
26												
27												
28												
29												
30												

L.V. Winding temp.-rise (K): $\Delta\theta_{wl} = (\theta_{wo} - \theta_{om_star}) \times \left(\frac{I_{rated}}{I_{start}}\right)^y + \Delta\theta_{om} = (55.1 - 45.2) \times \left(\frac{51.09}{52.92}\right)^{1.6} + 34.7 = 44.1$

Test Report

No: CTQC/B-25.0435
Total 38 Page 15

Temperature curve

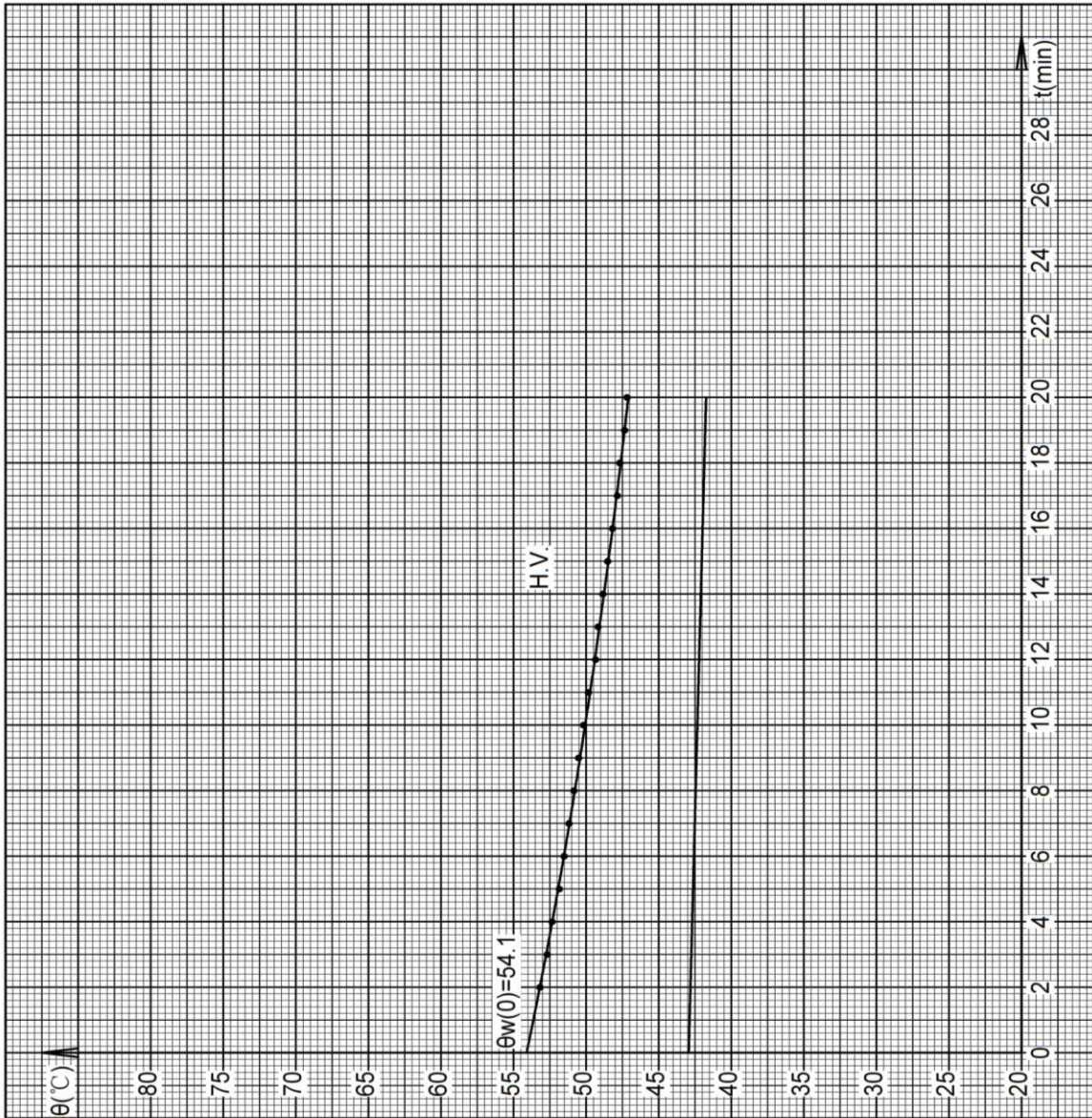

Test Report

No: CTQC/B-25.0435

Total 38 Page 16

Temperature curve

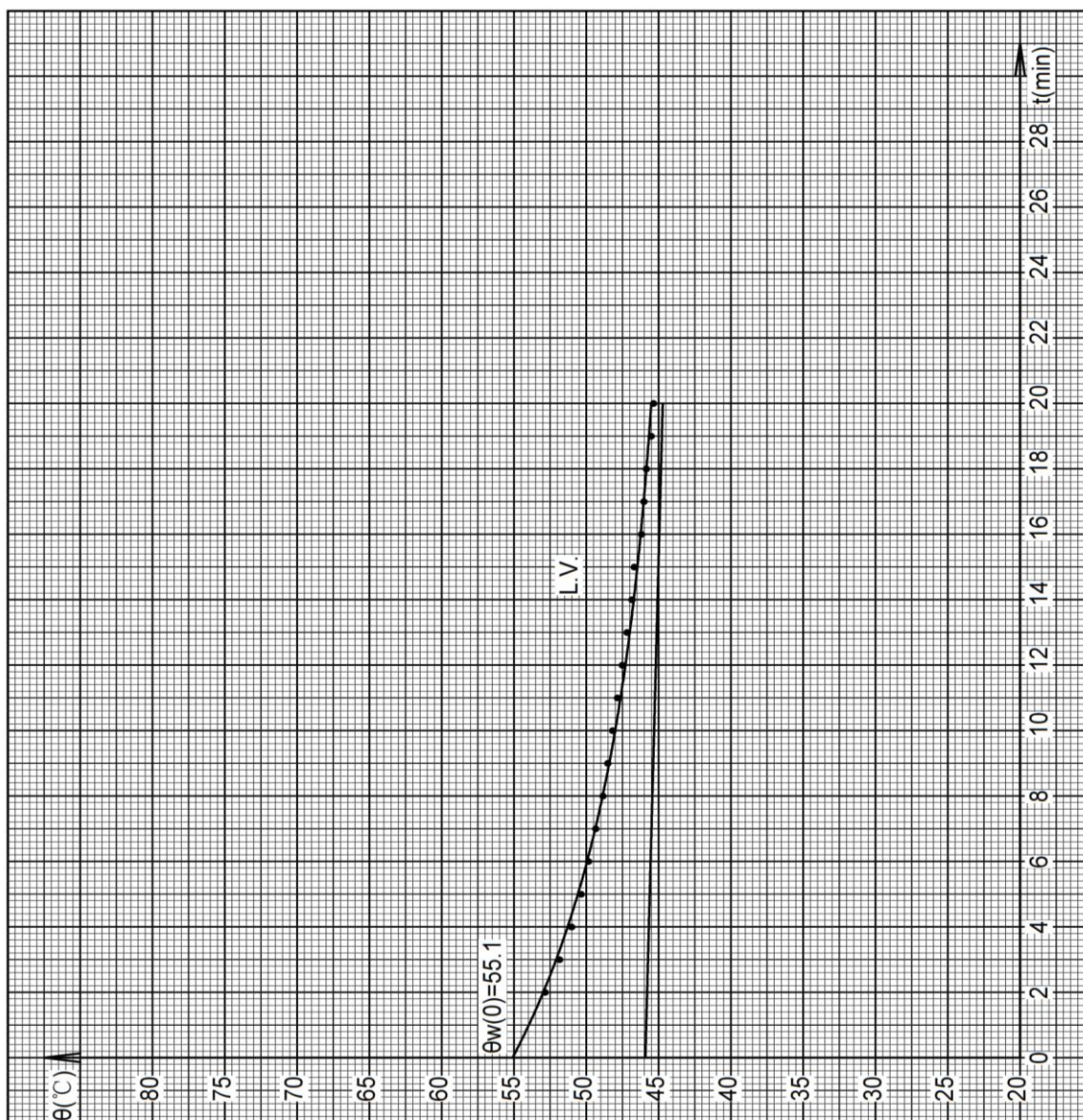

Test Report													№: CTQC/B-25. 0435				
													Total 38 Page 17				
4.16 Short-circuit withstand test(Special test)													Test date: Jan. 16, 2026				
4.16.1 Calculated short-circuit current(Reference temperature 75°C)													Ambient temperature: 11.2°C				
Tap position	HV(A)						LV(kA)						Peak factor ($K\sqrt{2}$)				
	The first peak of the asymmetrical short-circuit current			The r.m.s. value of the symmetrical short-circuit current			The first peak of the asymmetrical short-circuit current			The r.m.s. value of the symmetrical short-circuit current							
1	844			333			86.99			34.32			2.535				
3	879			347			88.87			35.10			2.532				
5	920			364			91.27			36.10			2.528				
4.16.2 Measurement of short-circuit current																	
Test circuit is given in Annex 2-f																	
Perform three-phase test, total 9 times, test waveshapes had no distortion. Test oscillograms were shown in pages 28~36.																	
The percentage of the first peak of the asymmetrical short-circuit value and the r.m.s. value of the symmetrical short-circuit current of HV is the ratio of corrected value to calculated current, the percentage of the first peak of the asymmetrical short-circuit value and the r.m.s. value of the symmetrical short-circuit current of HV is the ratio of measured value to calculated current.																	
Corrected value=Measured value/1.5																	
Tap position	Phase	№.	Measurement of current														
			The first peak of the asymmetrical short-circuit current						The r.m.s. value of the symmetrical short-circuit current						Oil tank to earth current (A)	Duration (s)	Wave serial №
			HV			LV			HV			LV					
			Measured value(A)	Corrected value (A)	(%)	Measured value(kA)	(%)	Measured value(A)	Corrected value (A)	(%)	Measured value(kA)	(%)					
1	AB	1	1267	845	100.1	86.79	99.8	481	321	96.4	33.94	98.9	0	1.0	B250435-S01-1		
		2	1262	841	99.6	85.17	97.9	484	323	97.0	34.62	99.8	0	1.0	B250435-S01-2		
		3	1281	854	101.2	85.00	97.7	487	325	97.6	34.51	100.6	0	1.0	B250435-S01-3		
	Before	№.	Measurement of reactance														
			Phase reactance value(Ω)						Deviation of phase reactance(%)								
			A		B		C		A		B		C				
			67.61		67.32		66.29		/		/		/				
1			67.55		67.35		66.23		<0.1		<0.1		<0.1				
2		67.55		67.35		66.23		<0.1		<0.1		<0.1					
3		67.55		67.35		66.23		<0.1		<0.1		<0.1					

Test Report													№: CTQC/B-25. 0435		
													Total 38 Page 18		
Tap position	Phase	№.	Measurement of current												
			The first peak of the asymmetrical short-circuit current					The r.m.s. value of the symmetrical short-circuit current					Oil tank to earth current (A)	Duration (s)	Wave serial №
			HV			LV		HV			LV				
			Measured value(A)	Corrected value (A)	(%)	Measured value(kA)	(%)	Measured value(A)	Corrected value (A)	(%)	Measured value(kA)	(%)			
3	BC	1	1317	878	99.9	89.46	100.7	497	331	95.4	34.70	98.9	0	1.0	B250435-S02-1
		2	1287	858	97.6	87.67	98.6	497	331	95.4	34.69	98.9	0	1.0	B250435-S02-2
		3	1317	878	99.9	89.63	100.9	497	331	95.4	34.75	99.0	0	1.0	B250435-S02-3
	№.	Measurement of reactance													
		Phase reactance value(Ω)						Deviation of phase reactance(%)							
		A	B	C	A	B	C								
		Before	64.89	64.51	63.58	/	/	/							
		1	64.94	64.65	63.53	<0.1	0.22	<0.1							
		2	64.92	64.73	63.52	<0.1	0.34	<0.1							
	3	64.92	64.73	63.52	<0.1	0.34	<0.1								

Test Report													№: CTQC/B-25. 0435				
													Total 38 Page 19				
Tap position	Phase	№.	Measurement of current														
			The first peak of the asymmetrical short-circuit current						The r.m.s. value of the symmetrical short-circuit current						Oil tank to earth current (A)	Duration (s)	Wave serial №
			HV			LV			HV			LV					
			Measured value(A)	Corrected value (A)	(%)	Measured value(kA)	(%)	Measured value(A)	Corrected value (A)	(%)	Measured value(kA)	(%)					
5	CA	1	1373	915	99.5	91.25	100.0	524	349	95.9	35.28	97.7	0	1.0	B250435-S03-1		
		2	1377	918	99.8	90.06	98.7	528	352	96.7	35.46	98.2	0	1.0	B250435-S03-2		
		3	1400	933	101.4	90.81	99.5	528	352	96.7	35.57	98.5	0	1.0	B250435-S03-3		
	№.	Measurement of reactance															
		Phase reactance value(Ω)						Deviation of phase reactance(%)									
		A	B	C	A	B	C										
		Before	61.86	61.48	60.64	/	/	/									
		1	61.89	61.70	60.58	<0.1	0.36	-0.10									
		2	61.89	61.61	60.67	<0.1	0.21	<0.1									
		3	61.88	61.59	60.57	<0.1	0.18	0.18									
Measurement of short-circuit reactance after S.C.T.																	
Tap position	Phase reactance value(Ω)						Deviation of phase reactance(%)										
	A	B	C	A	B	C											
1	67.70	67.42	66.39	0.13	0.15	0.15											
3	64.89	64.70	63.67	<0.1	0.29	0.14											
5	61.88	61.59	60.75	<0.1	0.18	0.18											
The maximum deviation of short-circuit reactance is 0.29%.																	

Test Report					No: CTQC/B-25. 0435			Total 38 Page 20	
4.16.3 Repeated routine tests after short-circuit withstand test									
4.16.3.1 Measurement of d. c. insulation resistance each winding to earth and between windings									
Test date: Jan. 18, 2026									
Humidity: 18.7%; Oil temperature: 10.6°C; Atmospheric pressure: 100.3kPa									
Measured position					Insulation resistance (GΩ)				
HV-LV&E					3.70				
LV-HV&E					2.57				
HV&LV-E					1.58				
HV-LV					3.75				
4.16.3.2 Measurement of voltage ratio and check of phase displacement									
Test date: Jan. 18, 2026									
Oil temperature: 10.6°C									
HV winding		LV winding		Ratio	Measured deviation(%)			Connection symbol	
Tap position	Voltage (kV)	Tap position	Voltage (kV)		AB/ab	BC/bc	CA/ca		
1	22.6	/	0.380	59.474	0.08	0.08	0.08	Dyn11	
2			0.384	59.008	0.10	0.10	0.10		
3			0.387	58.398	0.10	0.10	0.09		
4			0.391	57.801	0.08	0.08	0.08		
5			0.395	57.215	0.04	0.04	0.04		
Result: Passed.									
4.16.3.3 Measurement of winding resistance									
Test date: Jan. 18, 2026									
Oil temperature: 10.6°C									
Winding	Tap position	DC resistance(Ω)							
		A~B	B~C	C~A					
HV	1	0.8398	0.8398	0.8374					
	2	0.8303	0.8310	0.8283					
	3	0.8214	0.8217	0.8189					
	4	0.8119	0.8126	0.8101					
	5	0.8026	0.8030	0.8006					
LV	/	a~b	b~c	c~a					
		0.0002948	0.0002904	0.0003055					

Test Report					No: CTQC/B-25. 0435 Total 38 Page 21				
4. 16. 3. 4 Measurement of no-load loss and current					Test date: Jan. 19, 2026 Oil temperature: 10.2°C				
Voltage multiple	Phase voltage(kV)		No-load current		No-load loss(kW)				
	Mean	R.M.S.	(A)	(%)	Measured value	Corrected value			
100%U _r	0.228	0.229	2.55	0.09	1.28	1.27			
Result: Passed.									
4. 16. 3. 5 Measurement of short-circuit impedance and load loss					Test date: Jan. 20, 2026				
Winding	Tap position	Applied current		Measured voltage (kV)	Short-circuit impedance (Each phase)		Load loss (kW)		Total losses (kW)
					(Ω)	(%)	Measured value	Corrected value	Corrected value
		I (A)	I/I _r (%)		t=75°C	t=75°C I=I _r	t=10.5°C	t=75°C I=I _r	t=75°C I=I _r
HV LV	1	32.15	62.93	1.264	22.70	8.89	5.03	13.55	14.82
	2	32.75	64.10	1.259	22.19	8.69	5.12	13.29	14.56
	3	32.50	63.61	1.226	21.78	8.53	4.97	13.09	14.36
	4	33.26	65.10	1.224	21.25	8.32	5.09	12.82	14.09
	5	33.37	65.32	1.200	20.76	8.13	5.02	12.58	13.85
Result: Passed.									
4. 16. 3. 6 Test on dielectric liquid					Test date: Jan. 18, 2026 Humidity: 21.1%; Ambient temperature: 20.7°C				
Breakdown voltage(kV)		Water dissolved(mg/L)		Result					
65.9		30		Passed					

Test Report		No: CTQC/B-25.0435 Total 38 Page 22	
4.16.3.7 Lightning impulse test (Type test)		Test date: Jan 17, 2026	
Test circuit is given in Annex 2-g			
Test conditions: Humidity: 15.0%; Ambient temperature: 13.1°C; Atmospheric pressure: 102.6kPa.			
Test items and voltage			
Tested terminals	Rated withstand voltage(kV)		Tap position
	Full wave	Chopped wave	
A, B, C	125	138	5
<p>Applied voltage(kV): Full wave(kV): 121.9~128.1 Chopped wave(kV): 136.3~140.7</p> <p>Test sequence: Line terminal One reduced negative polarity full wave impulse; One rated negative polarity full wave impulse; Two rated negative polarity chopped wave impulses; Two rated negative polarity full wave impulses.</p> <p>Test oscillogram records: T1: Front time; T2: Time to half value; Tc: Time to chopping; Up2: Factor of over crossing; Up: Peak voltage.</p> <p>Result: Passed.</p>			

Test Report

No: CTQC/B-25. 0435

Total 38 Page 23

Tested terminal: A Test polarity: Negative CH1: Voltage records CH2: Neutral current records

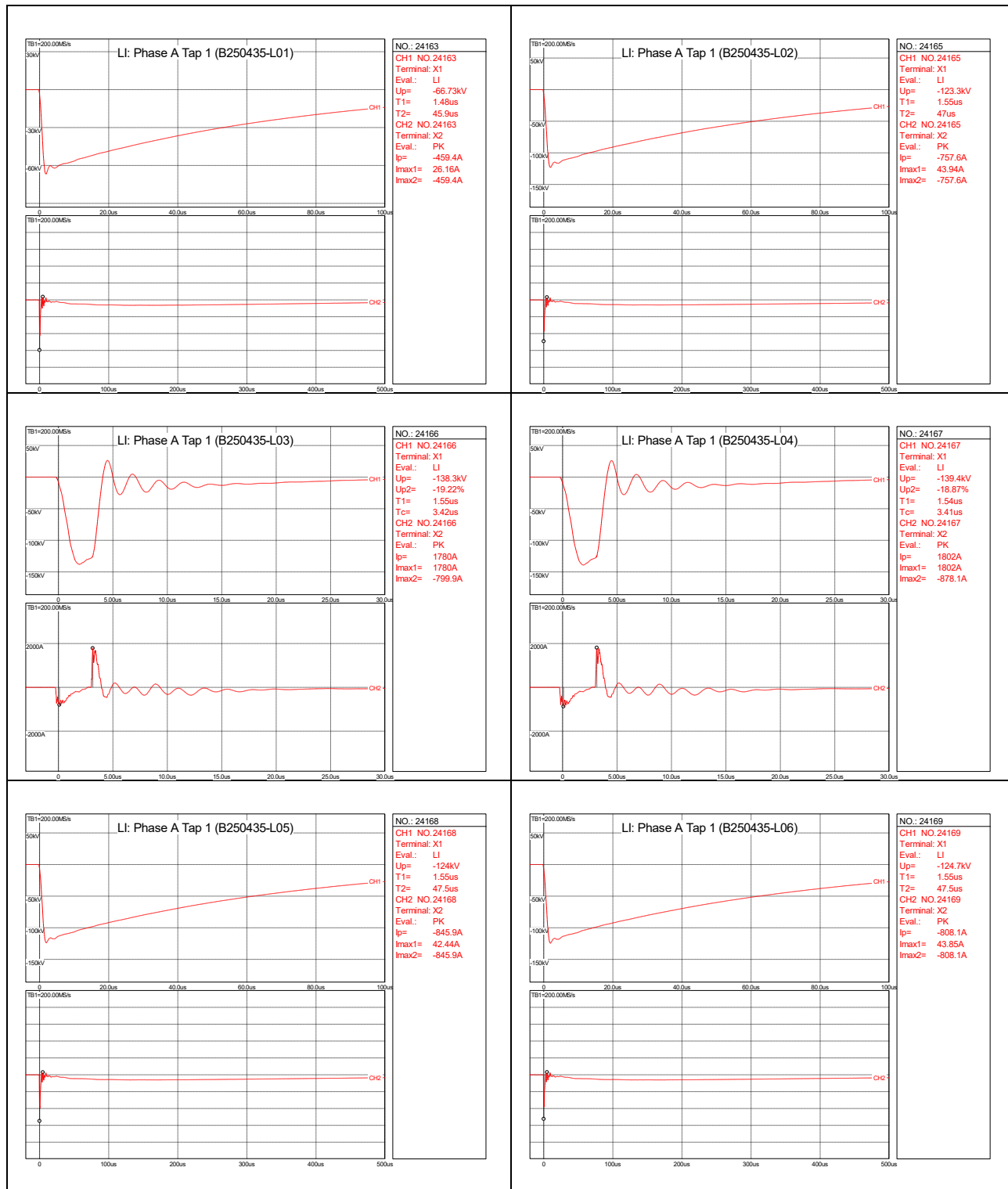

Test Report

No: CTQC/B-25.0435

Total 38 Page 24

Tested terminal: B; Test polarity: Negative; CH1: Voltage records; CH2: Neutral current records

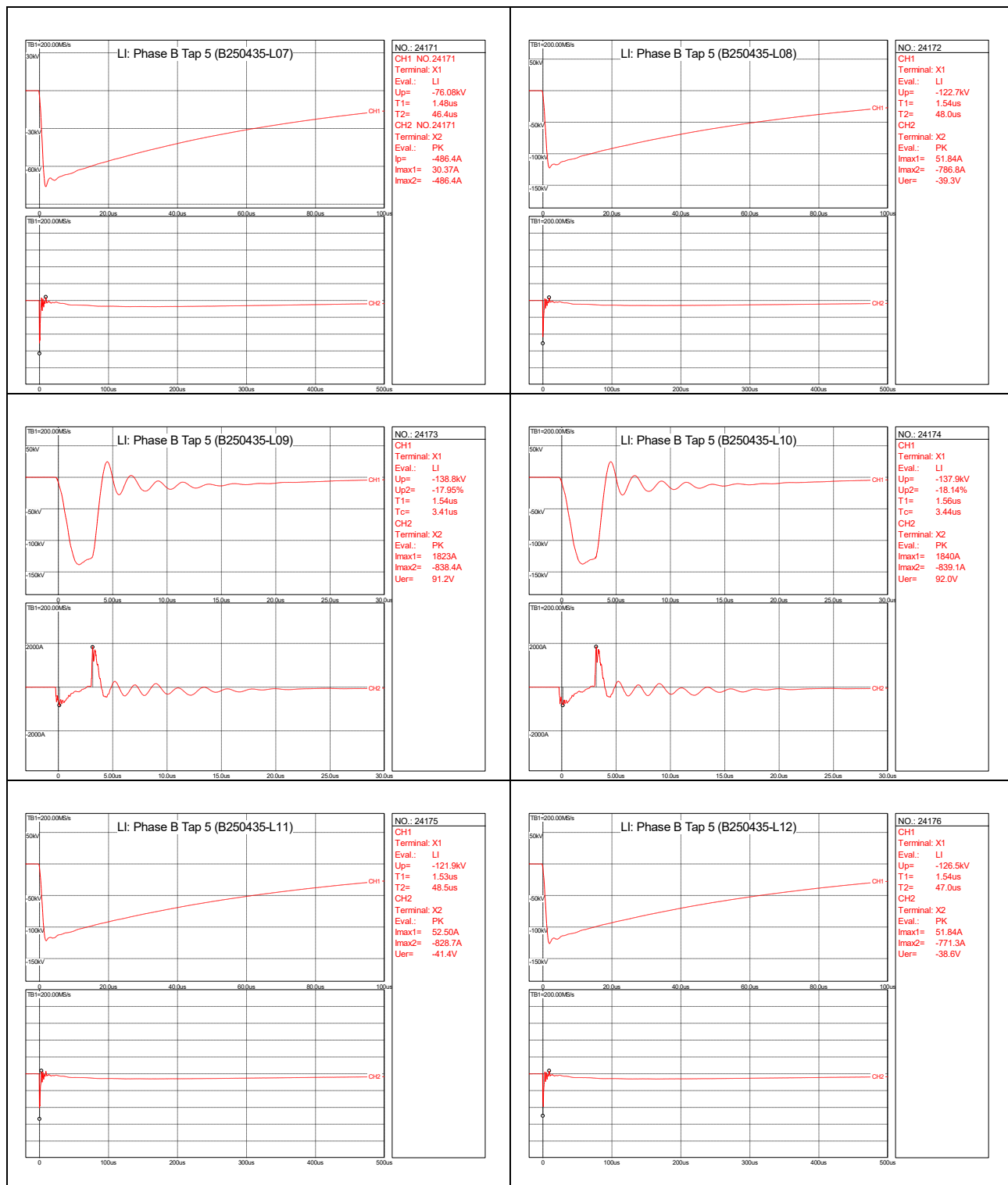

Test Report

No: CTQC/B-25.0435

Total 38 Page 25

Tested terminal: C; Test polarity: Negative; CH1: Voltage records; CH2: Neutral current records

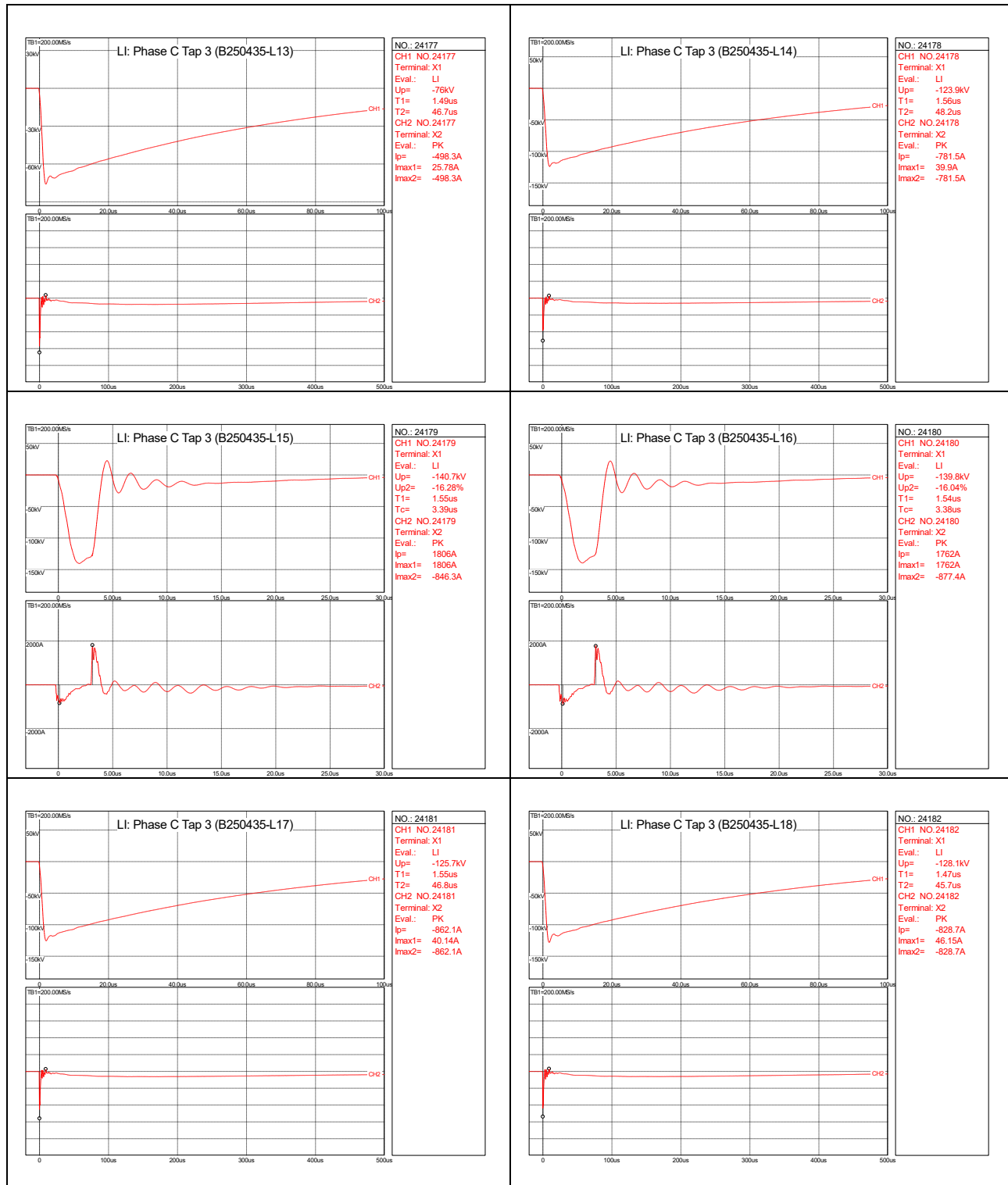

Test		Report		No: CTQC/B-25.0435 Total 38 Page 26		
4.16.3.8 Applied voltage test				Test date: Jan. 19, 2026 Humidity: 19.1%; Oil temperature: 10.2°C; Atmospheric pressure: 102.9kPa		
Measured position	Applied voltage(kV)	Duration(s)	Result			
HV-LV&E	50	60	Passed			
LV-HV&E	6	60				
AuxW	2	60				
4.16.3.9 Auxiliary wiring insulation test (AuxW) See 4.16.3.9						
4.16.3.10 Induced voltage withstand test				Test date: Jan. 19, 2026 Humidity: 19.1%; Oil temperature: 10.2°C; Atmospheric pressure: 102.9kPa		
Tap position	Applied voltage(kV)	Induced voltage(kV)	Multiple	Frequency (Hz)	Duration(s)	Result
	LV	HV				
5	0.79	45.2	2	150	40	Passed
4.16.4 The out of tank inspection There is no deformation of winding, connection and supporting structures, no traces of electrical discharge was found after S.C.T. The active part photos taken before and after S.C.T. were shown in pages 37~38.						
4.16.5 The result of short-circuit withstand test: passed.						

Test Report				No: CTQC/B-25.0435 Total 38 Page 27		
4.17 Measurement of zero-sequence impedance on three phase transformers (Special test)						
				Test date: Jan. 13, 2026		
Test circuit is given in Annex 2-h				Oil temperature: 11.2°C		
Tap position	Connection symbol	Supplied current terminal	Applied current (A)	Measured voltage (V)	Impedance(Ω)	
5	Dyn11	abc-n	440.2	1.0041	0.006843	
4.18 Induced voltage test with partial discharge measurement (IVPD) (Special test)						
				Test date: Jan. 19, 2026		
Tap position: HV 5, frequency: 150Hz.				Oil temperature: 10.2°C		
Applied voltage(kV)			Duration	Partial discharge level(pC)		
Multiple	HV	LV		A	B	C
$0.4U_r/\sqrt{3}$	5.22	0.091	/	<10	<10	<10
$1.2U_r/\sqrt{3}$	15.66	0.274	1min	<10	<10	<10
$U_2=1.58U_r/\sqrt{3}$	20.62	0.360	5min	<10	<10	<10
$U_1=2.0U_r/\sqrt{3}$	26.10	0.456	40s	/	/	/
$U_2=1.58U_r/\sqrt{3}$	20.62	0.360	5min	<10	<10	<10
$1.2U_r/\sqrt{3}$	15.66	0.274	1min	<10	<10	<10
$0.4U_r/\sqrt{3}$	5.22	0.091	/	<10	<10	<10
Result: Passed.						

Test Report

No: CTQC/B-25.0435

Total 38 Page 28

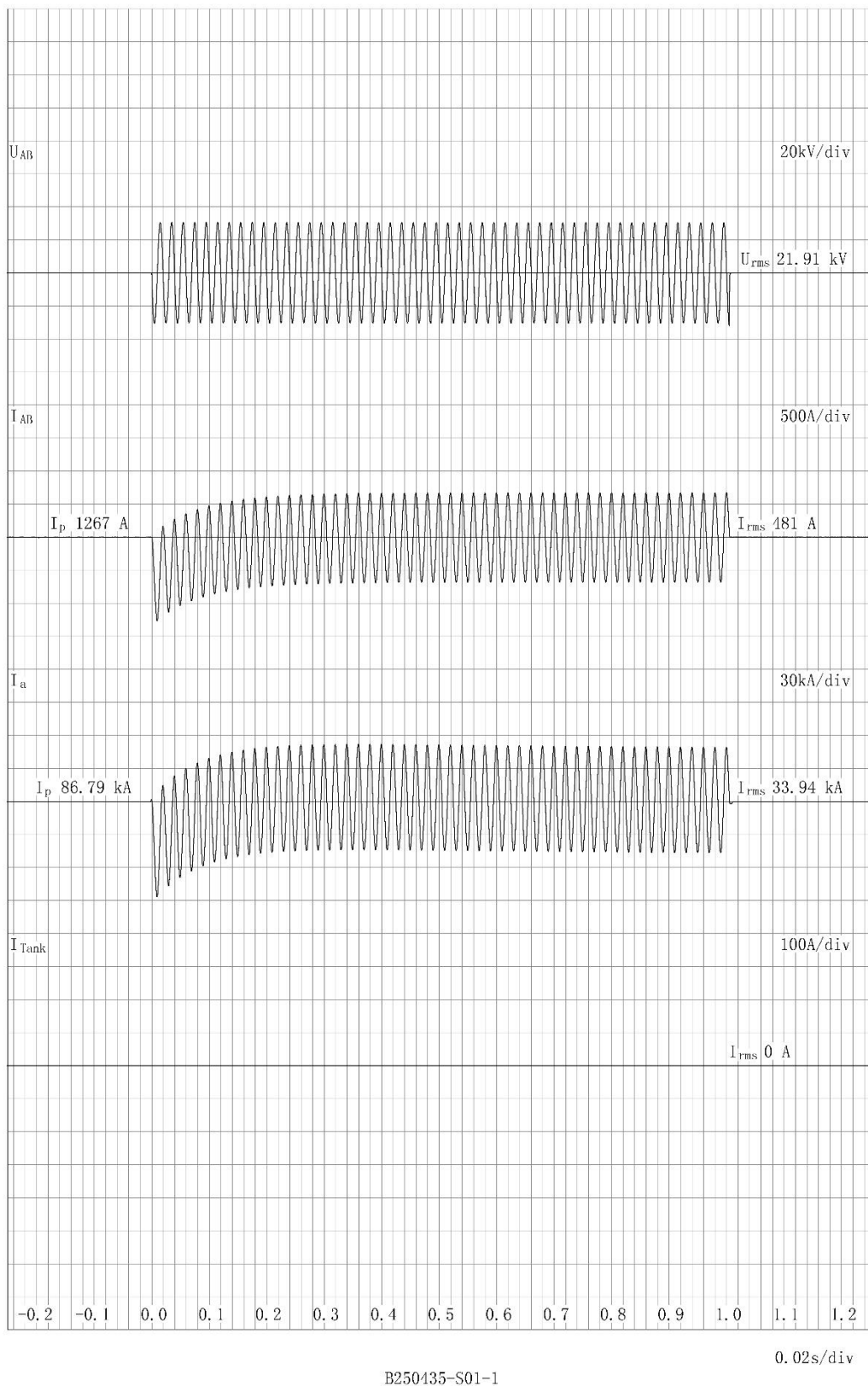

B250435-S01-1

Test Report

No: CTQC/B-25.0435

Total 38 Page 29

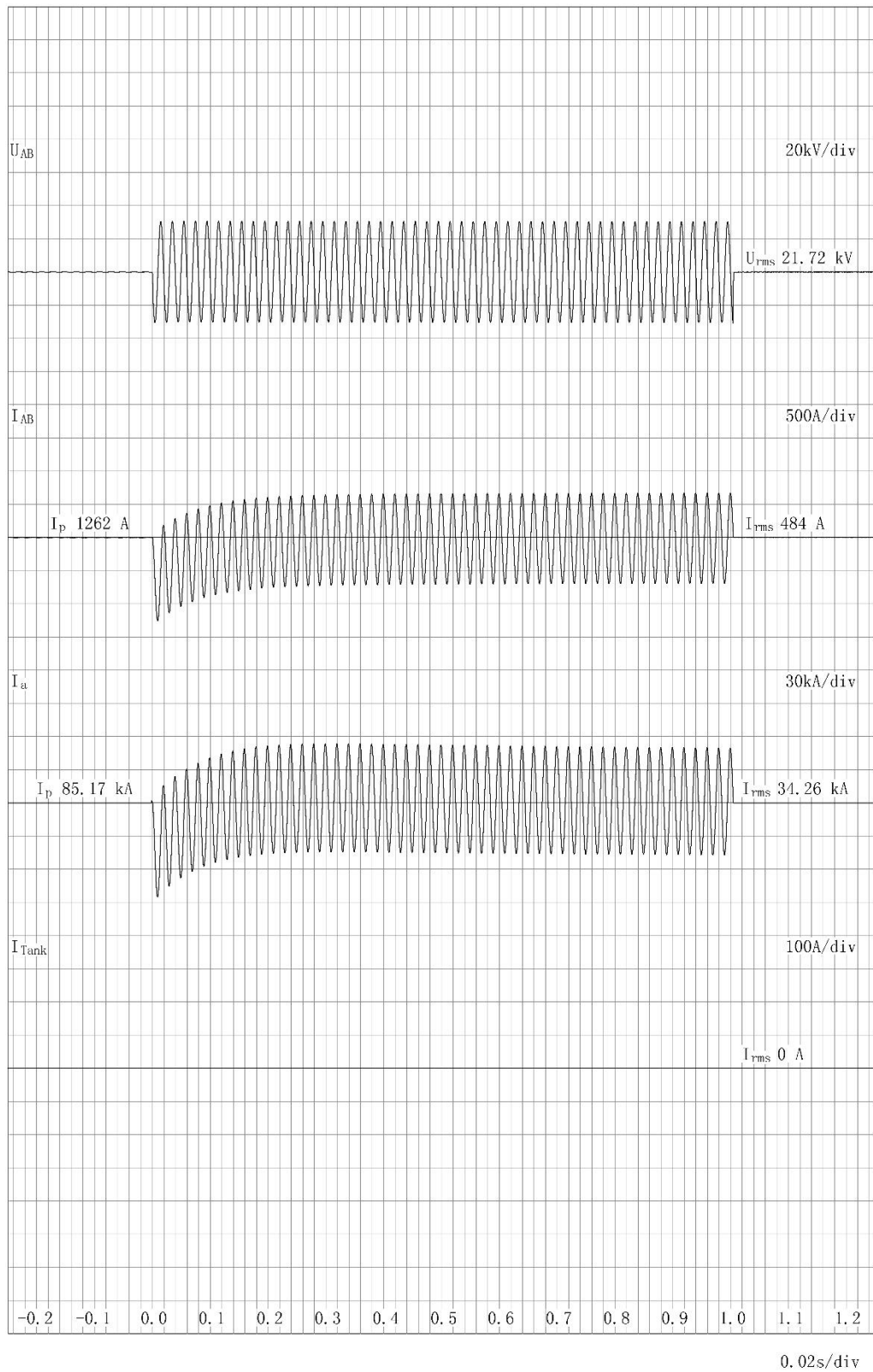

B250435-S01-2

Test Report

No: CTQC/B-25.0435

Total 38 Page 30

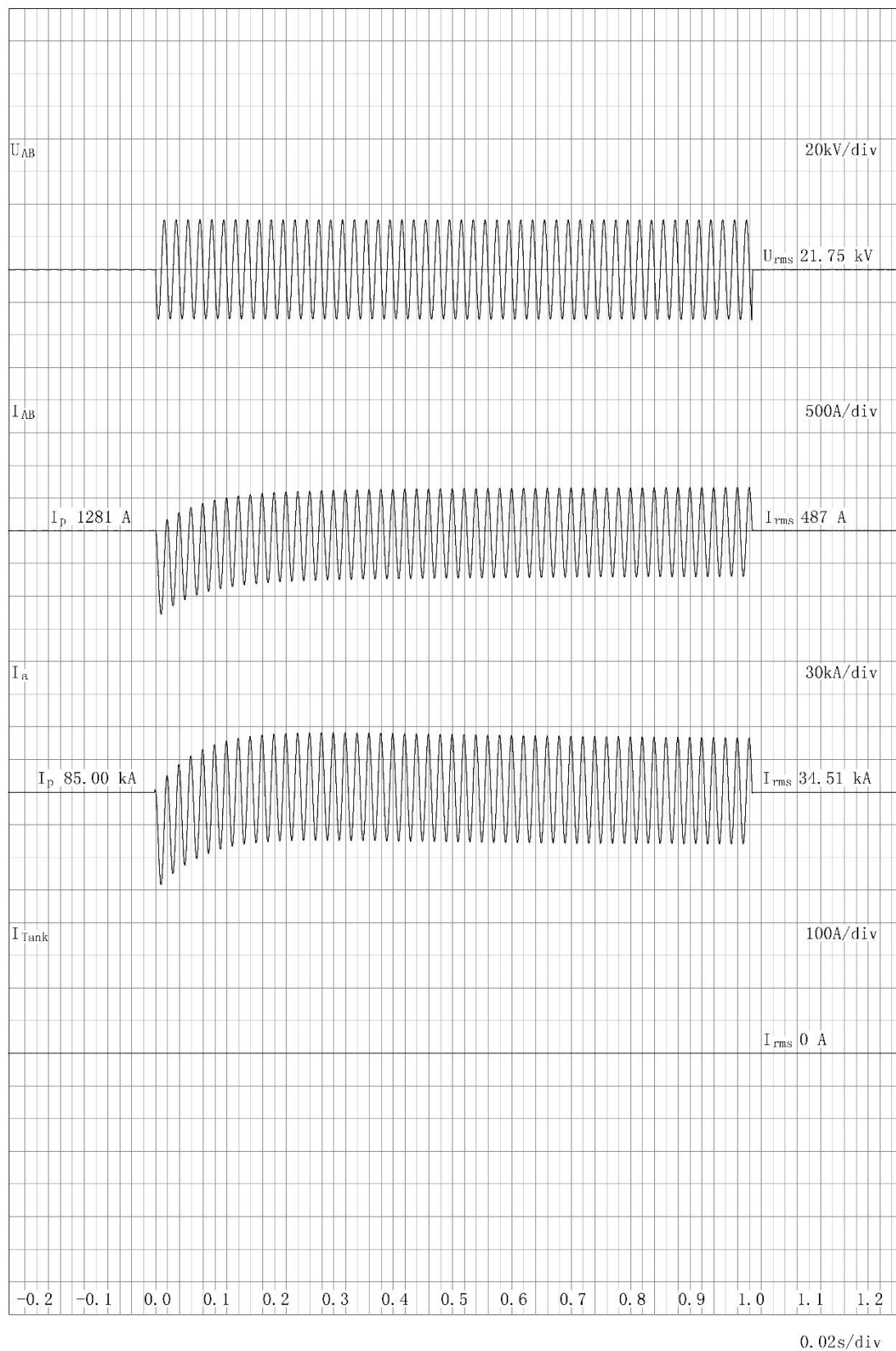

B250435-S01-3

Test Report

No: CTQC/B-25.0435

Total 38 Page 31

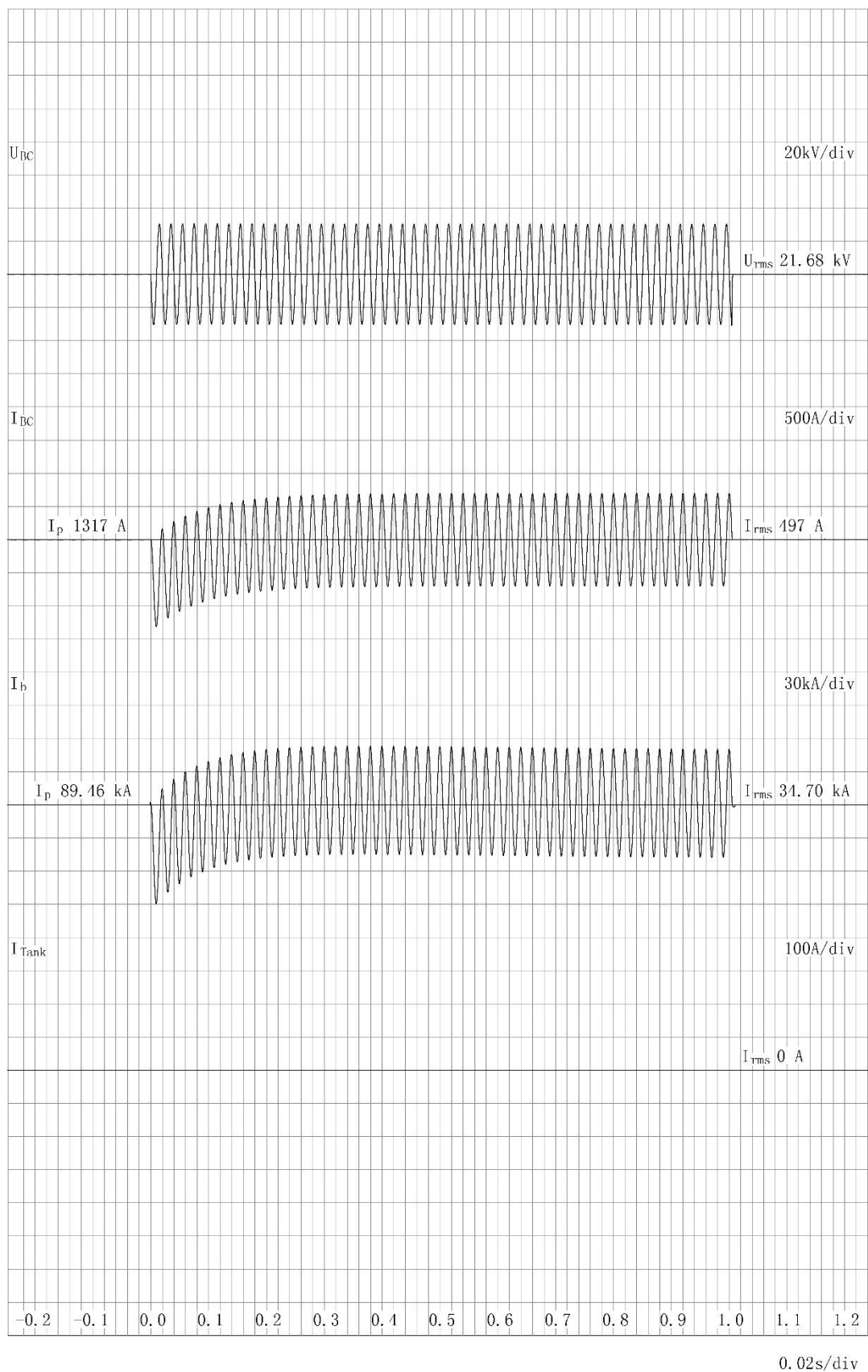

B250435-S02-1

Test Report

No: CTQC/B-25.0435

Total 38 Page 32

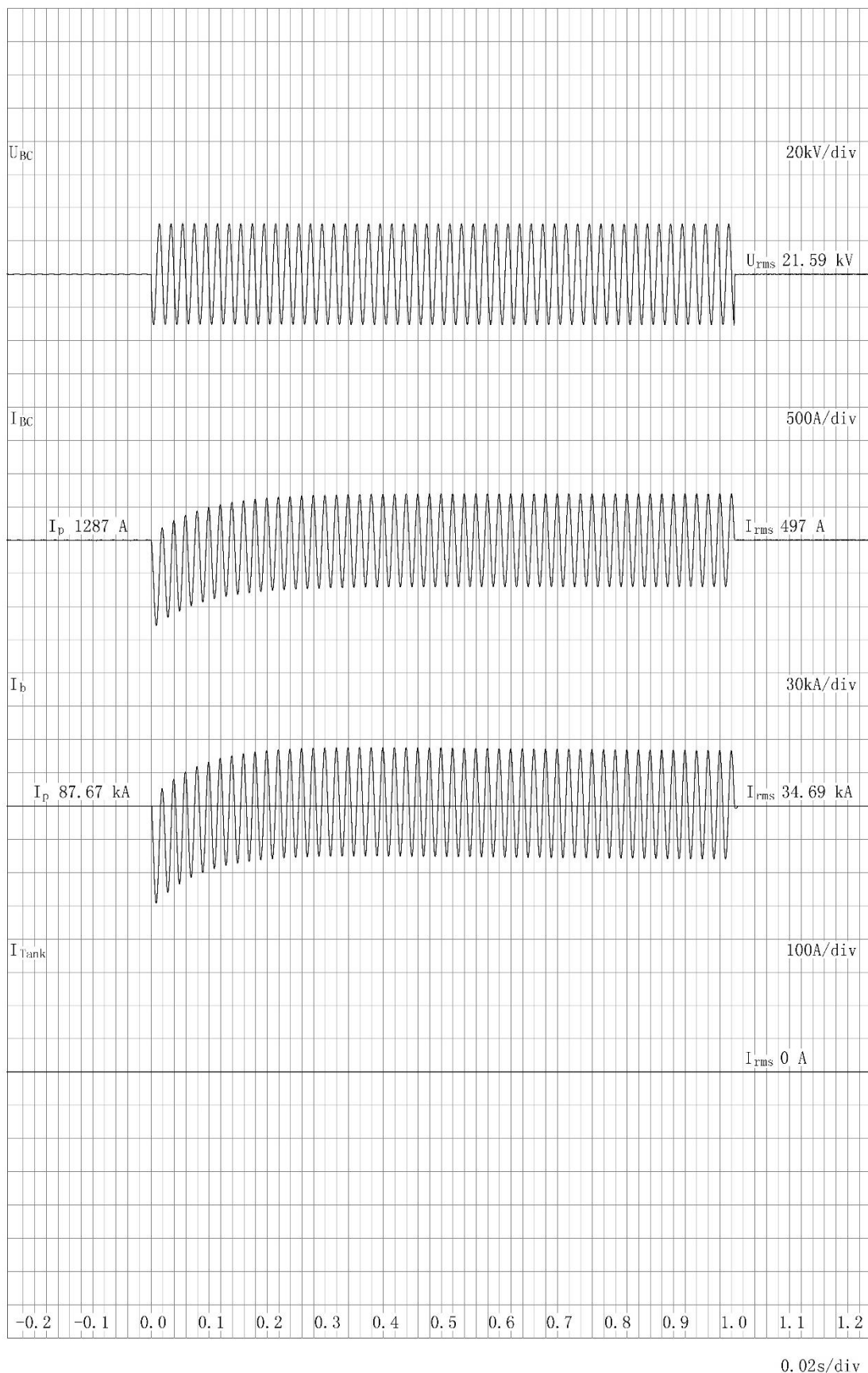

B250135-S02-2

Test Report

No: CTQC/B-25.0435

Total 38 Page 33

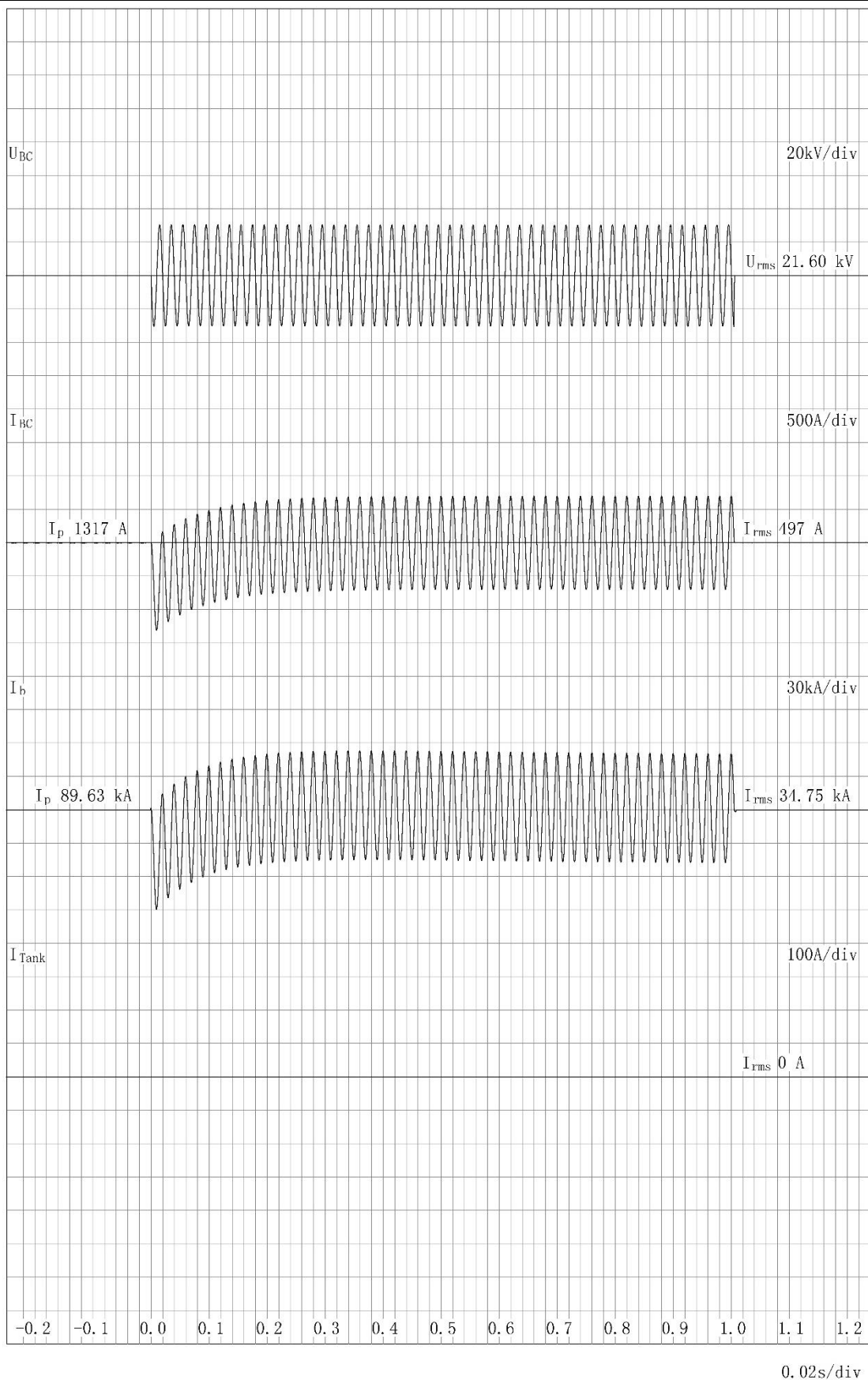

B250135-S02-3

Test Report

No: CTQC/B-25.0435

Total 38 Page 34

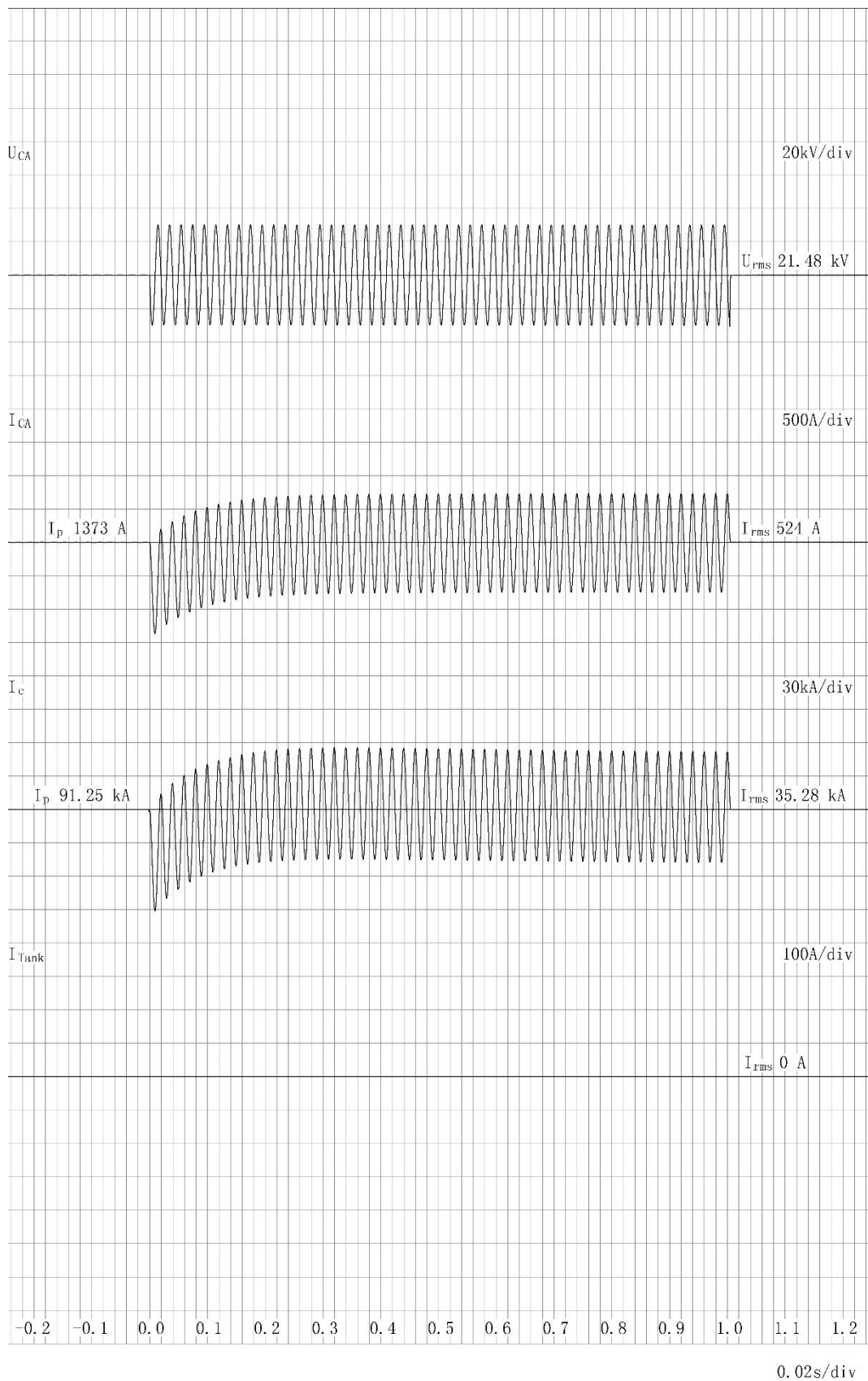

B250435-S03-1

Test Report

No: CTQC/B-25.0435

Total 38 Page 35

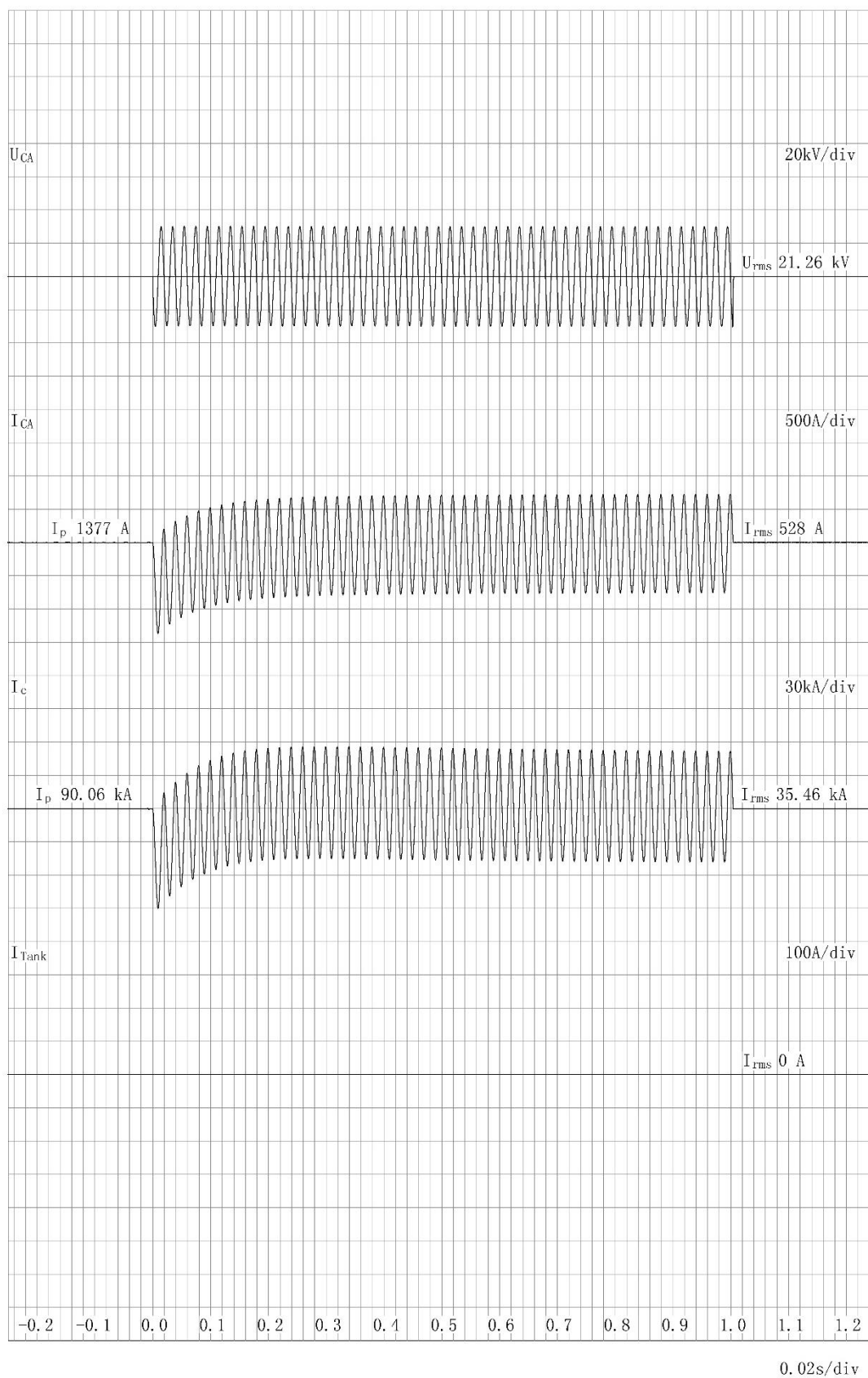

B250435-S03-2

Test Report

No: CTQC/B-25.0435

Total 38 Page 36

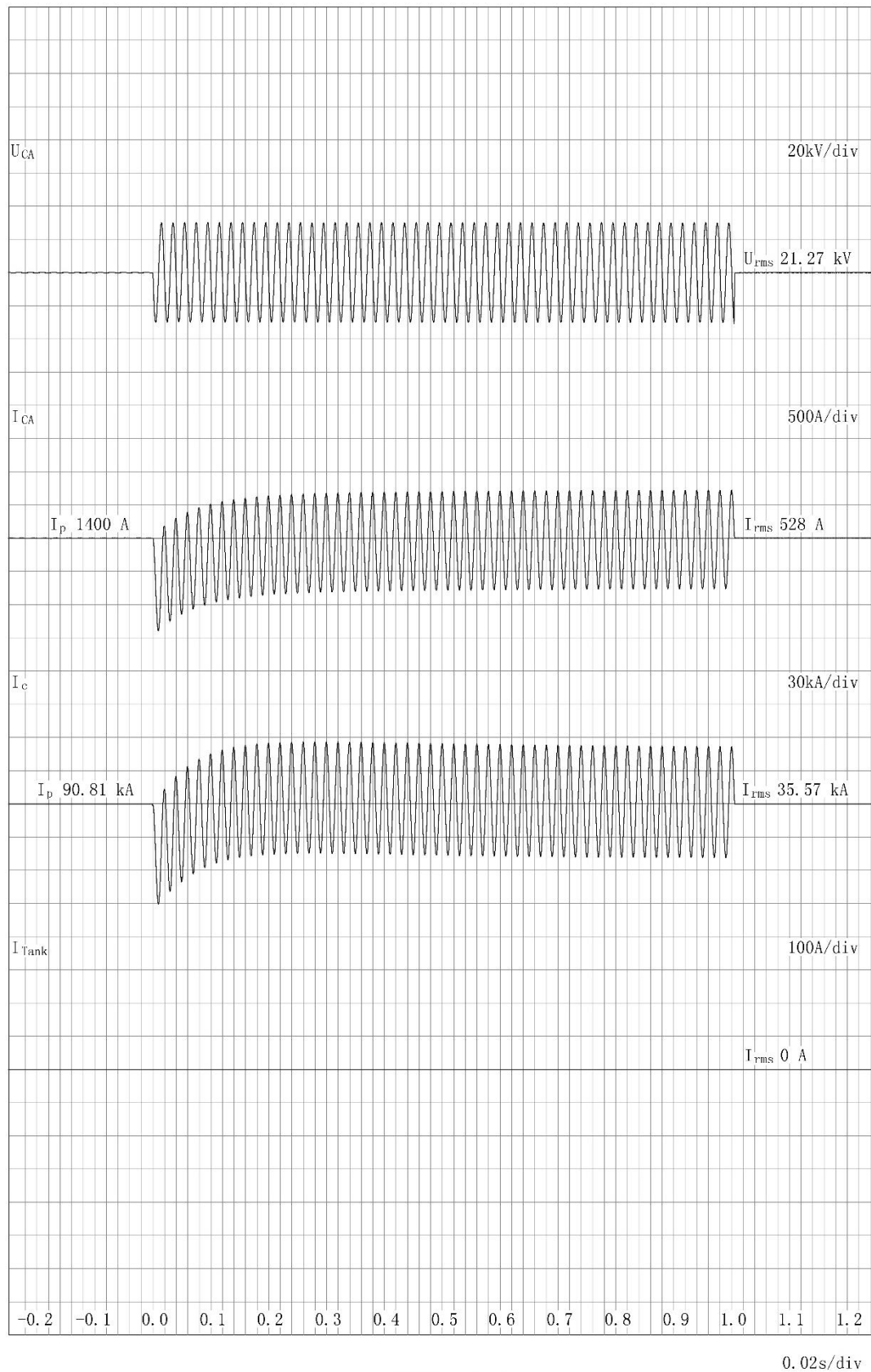

B250435-S03-3

Test Report

No: CTQC/B-25.0435

Total 38 Page 37

HV Before S.C.T.:



LV Before S.C.T.:



Test Report

No: CTQC/B-25.0435

Total 38 Page 38

HV After S.C.T.:

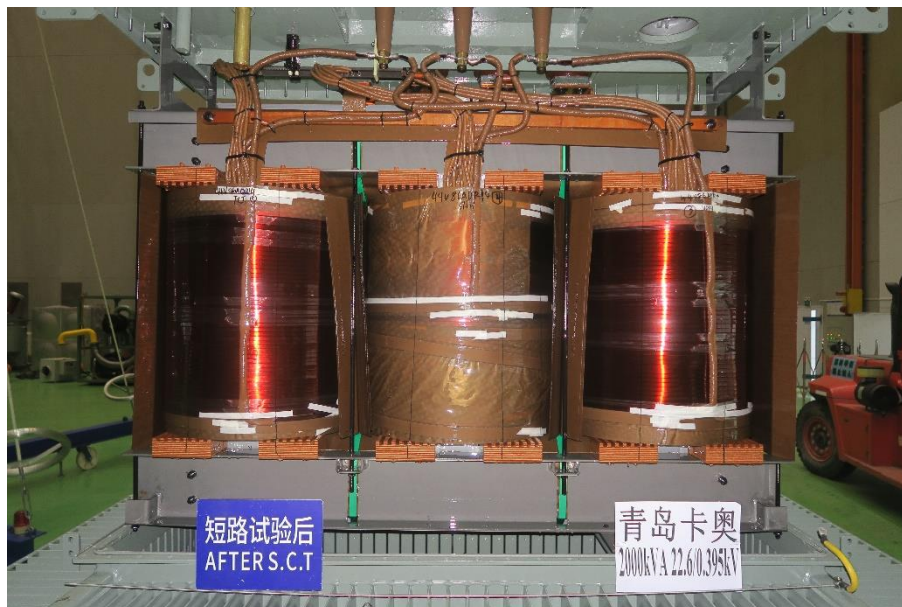

LV After S.C.T.:

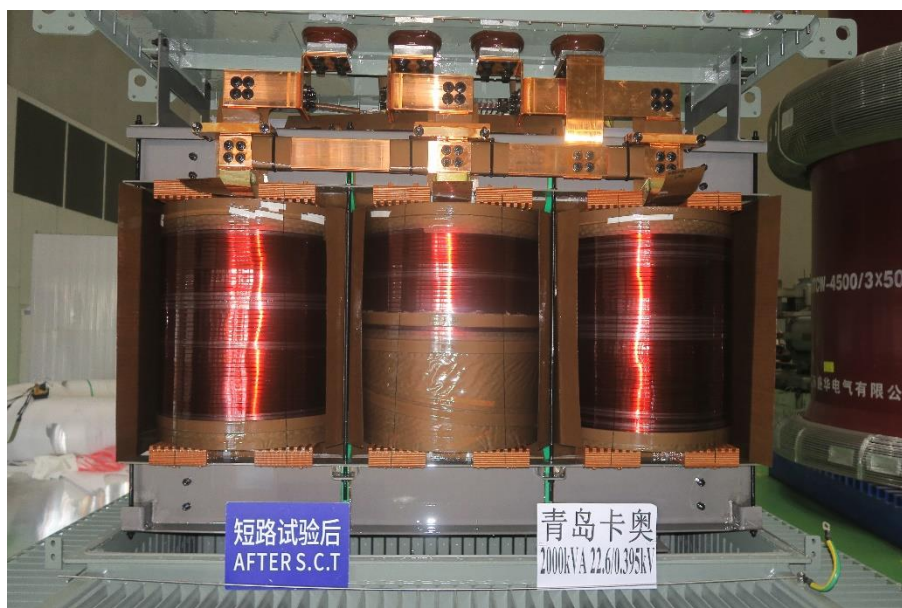

RATING PLATE AND OUTLINE PHOTOS

TEST CIRCUITS

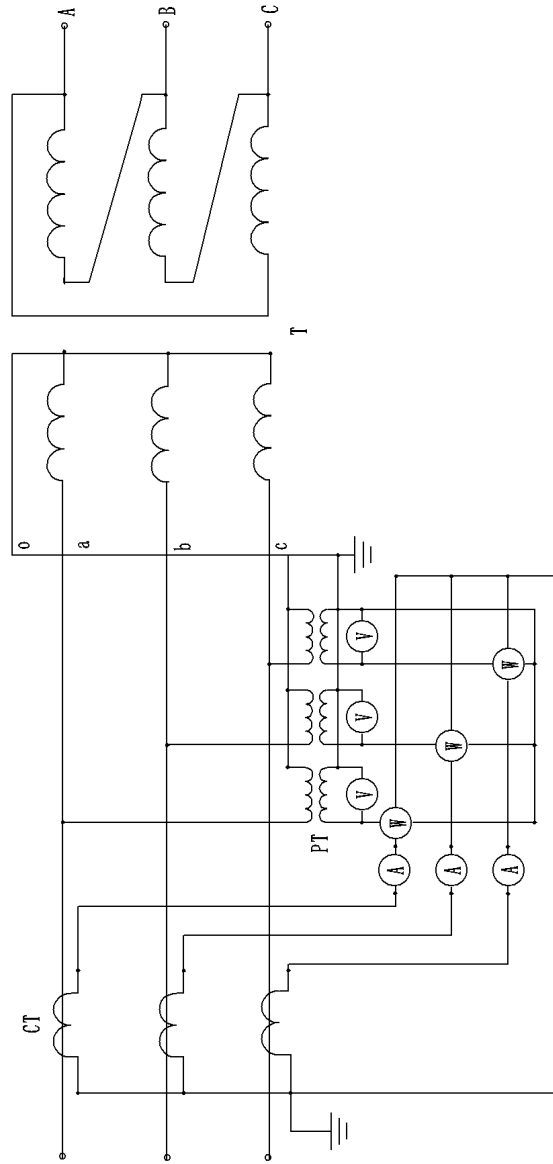

空载损耗及空载电流测量线路图

No-load loss and current measurement circuit

T-被试变压器 Sample CT-电流互感器 Current transformer
 PT-电压互感器 Voltage transformer A-电流表 Ammeter
 W-瓦特表 Wattmeter V-电压表 voltmeter

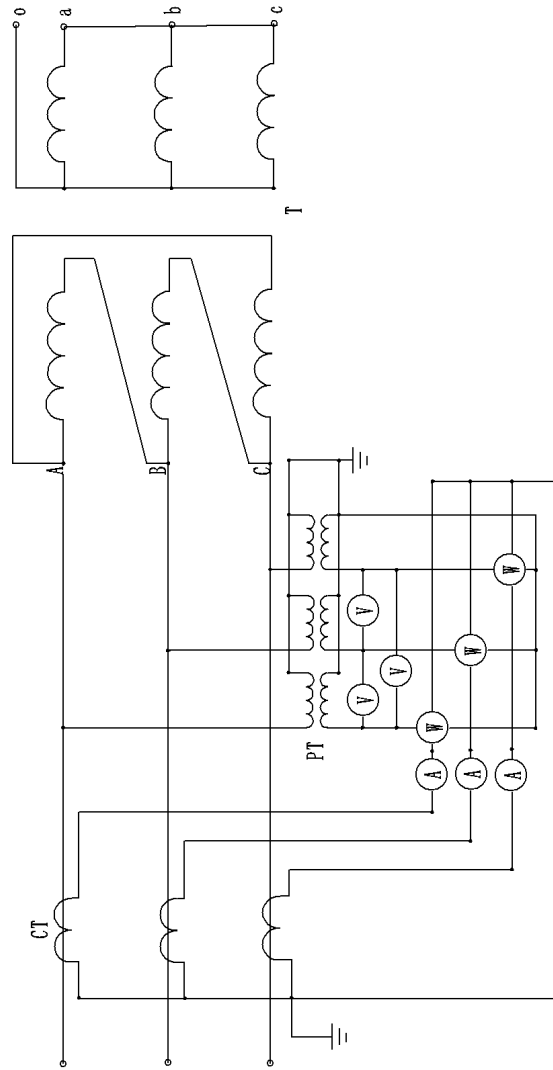

短路阻抗及负载损耗测量线路图

Short circuit impedance and on load loss measurement circuit

T-被试变压器 Sample

CT-电流互感器 Current transformer

A-电流表 Amperemeter

PT-电压互感器 Voltage transformer

W-瓦特表 Wattmeter

V-电压表 Voltmeter

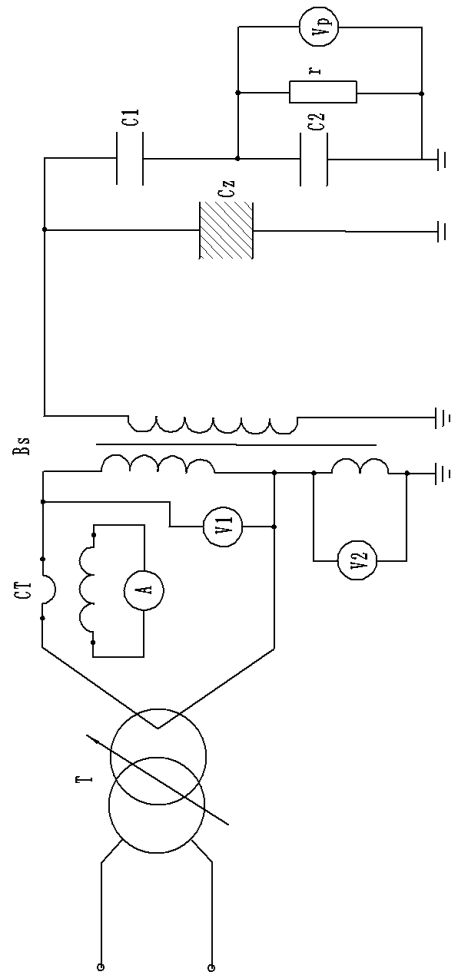

外施耐压试验线路图

Separate-source voltage withstand diagram

- | | | | | | |
|-------------|----------------------|------------|----------------------|----------|---------------------|
| T-调压器 | Regulator | A-电流表 | Amperemeter | Bs-试验变压器 | Testing transformer |
| CT-电流互感器 | Current transformer | V1, V2-电压表 | Voltmeter | | |
| C1, C2-分压电容 | Capacitive divider | Cz-试品 | Sample | | |
| r-放电电阻 | Discharge resistance | Vp-峰值电压表 | Peak value voltmeter | | |

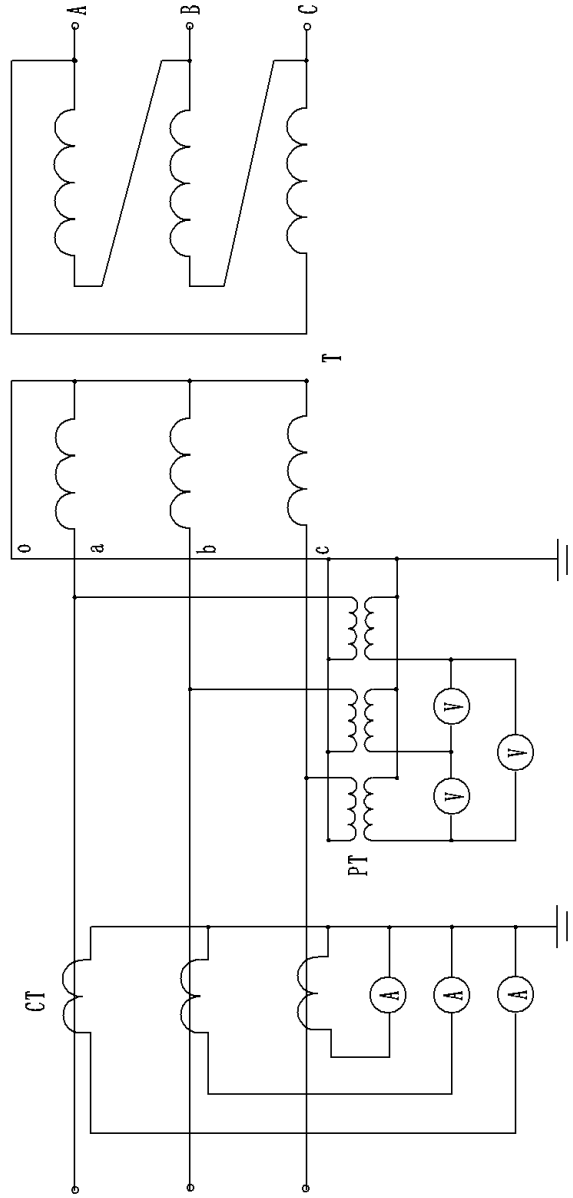

感应耐压试验线路图

Induced overvoltage withstand test circuit

- | | | | |
|----------|---------------------|----------|---------------------|
| T-被试变压器 | Sample | CT-电流互感器 | Current transformer |
| PT-电压互感器 | Voltage transformer | A-电流表 | Amperemeter |
| V-电压表 | Voltmeter | | |

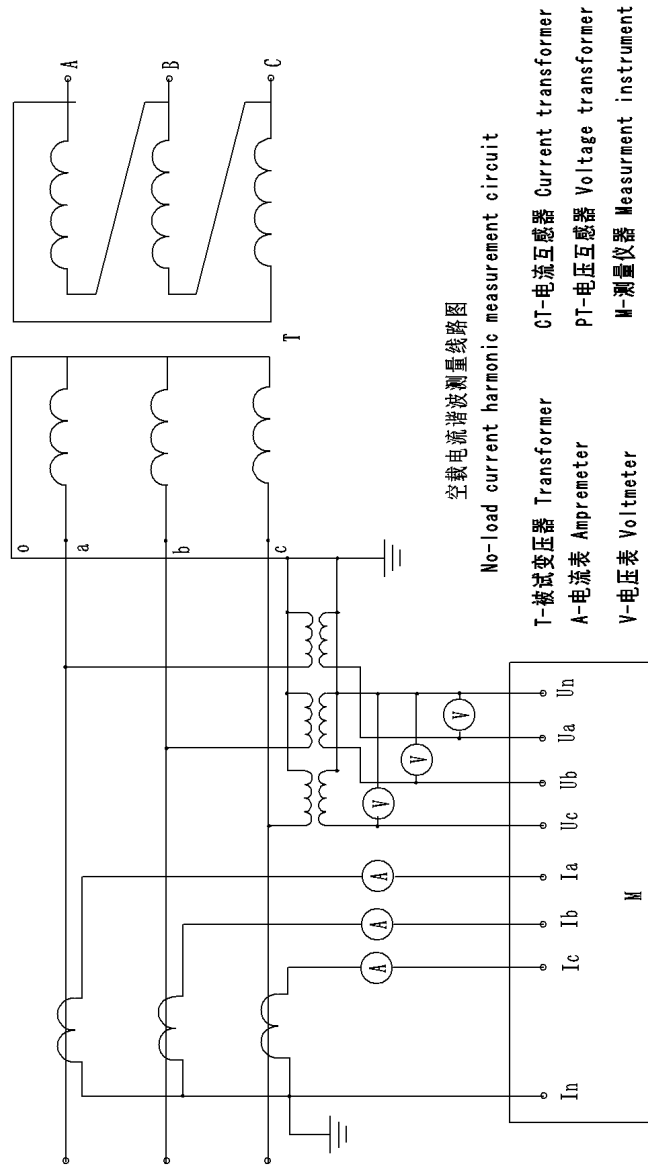

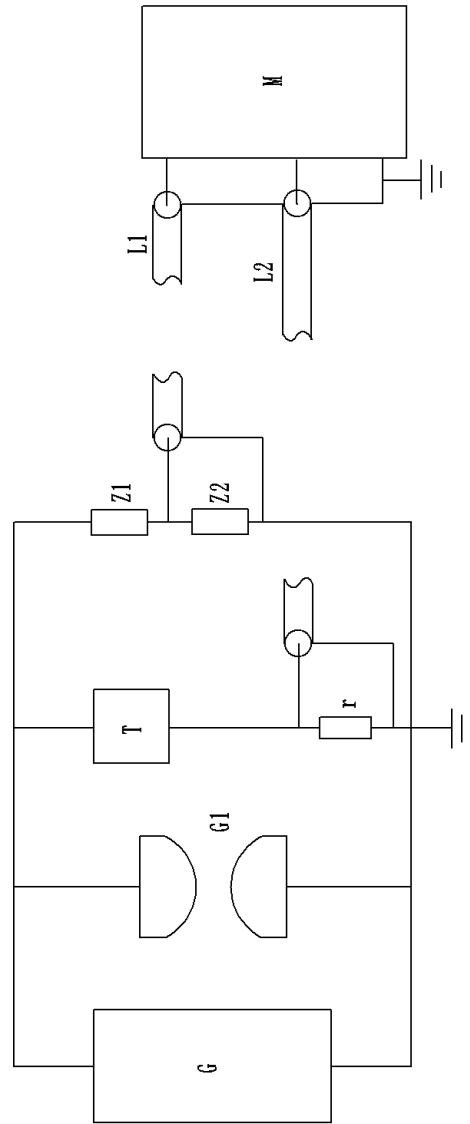

雷电冲击试验接线图
Lightning impulse withstand test system circuit

- | | | | |
|---------------|-----------------------------------|---------|------------------------|
| G-冲击电压发生器 | Impulse generator | G1-截断装置 | Chopping device |
| Z1, Z2-阻容分压器 | Voltage divider | M-测量仪器 | Measurement instrument |
| L1, L2-高频传输电缆 | High frequency transmission cable | T-试品 | Sample |
| r-分流器 | Shunt | | |

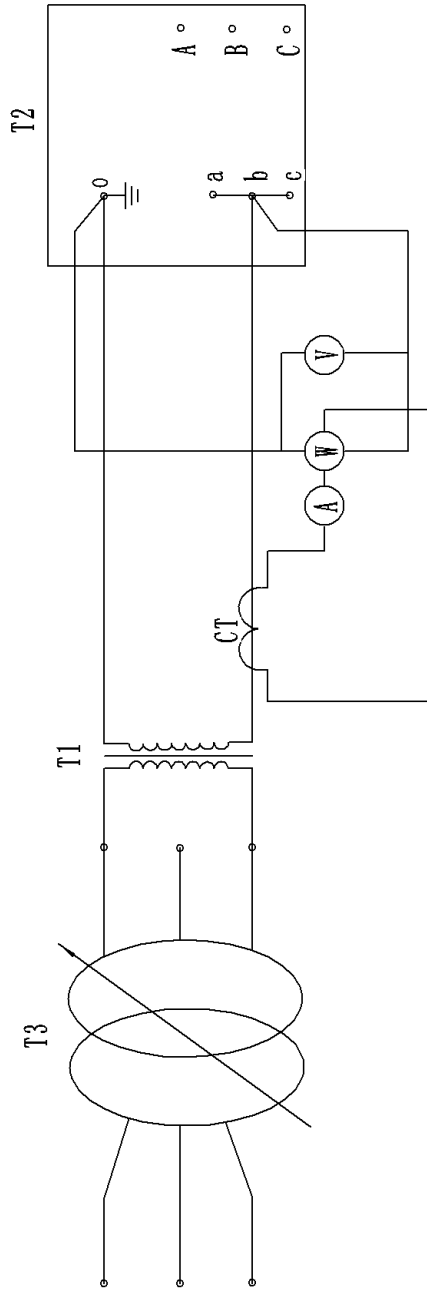

变压器零序阻抗测量线路图

Zero-sequence impedance measurement circuit

T1-大电流变压器 Heavy current testing transformer

T3-调压器 Regulator

W-瓦特表 Wattmeter

T2-被试变压器 Sample

A-电流表 Amperemeter

CT-电流互感器 Current transformer

V-电压表 Voltmeter

TRANSFORMER DRAWINGS

2025.12.18

124

4-Ø5

CAHORS

QINGDAO CAHORS ELECTRICAL EQUIPMENT CO., LTD
 197, Pingshan Road, Qingdao E & T Dept Zone, 266500, Qingdao, Shandong, China
 Tel: +86(0)532 8690 7069 / +86(0)532 8690 7072

TRANSFORMER 3 Phase Transformer

LOSSES 1320/13500W **HERMETICALLY SEALED** YES 50 Hz

ACCORDING TO IEC 60076

REFERENCE 7300015177 **N°**

YEAR **MAGNETIC CORE** FeSi 2105 **kg**

CONDUCTOR COPPER 1950 **kg** ALUMINIUM NA **kg**

INSULATION LEVELS HV 24 / 50 / 125 LV 1.1 / 6 / 6 **kV**

RATED POWER 2000

CONNECTION SYMBOL Dyn11

MAX SYSTEM SHORT CIRCUIT POWER 350 **MVA**

IMPEDANCE VOLTAGE % **MAX AMBIENT TEMP.** 50 **°C**

TEMPERATURE RISE OIL 45 **K** **WINDING** 50 **K**

HIGH VOLTAGE		LOW VOLTAGE	
22600	V	51.09	A
1	380	V	3039
2	383.8	V	3009
3	387.6	V	2979
4	391.4	V	2950
5	395.2	V	2922

COOLING KNAN

DIELECTRIC TYPE FR3-IEC62770 **DIELECTRIC MASS** 1490* **kg**

DIELECTRIC VOLUME 1620* **L** **TOTAL MASS** 7790* **kg**

40149310R14 **MADE IN** PRC

235

CLP Power Hong Kong Limited
CATEGORY 'I'
APPROVED

Date: 18 December 2025
 This approval does not relieve the responsibility of manufacturer / contractor in ensuring correctness and appropriateness of all data on this drawing / document
 Signed by: *[Signature]*
 Information Class: PROPRIETARY

NOTES

1. Material: 316L thickness: 1mm;
2. The blank with * will be adjusted according to actual value;
3. Impedance voltage will imprint measured value.

黃程

CLP 中電	REV.	DESCRIPTION	DATE	CHK.
	TITLE: NATURAL ESTER(FR3) IMMERSSED DISTRIBUTION TRANSFORMER 2000kVA 22.6/0.395kV KNAN RATING PLATE			
CONTRACTOR: Qingdao Cahors Electrical Equipment Co., Ltd.				
DRAWN: LY	DATE: 20251212			
CHECKED: QWJ	APPROVED: S.J			
SCALE:	SHEET(S) IN SET: 3/26	PROJECT NO.: 7300015177	CONTRACT NO.: 7300015177	
ASSET MANAGEMENT				
DRG. NO. T / S D D / 5 4 9 1 0 / D C H R / 0 0 0 1 / 0 3 / S				

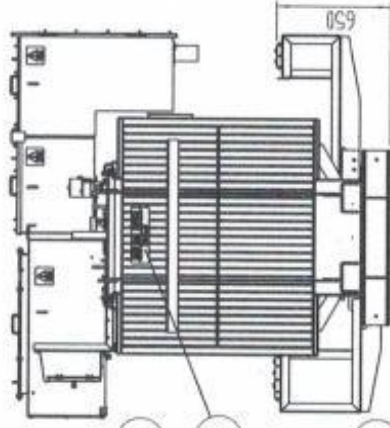
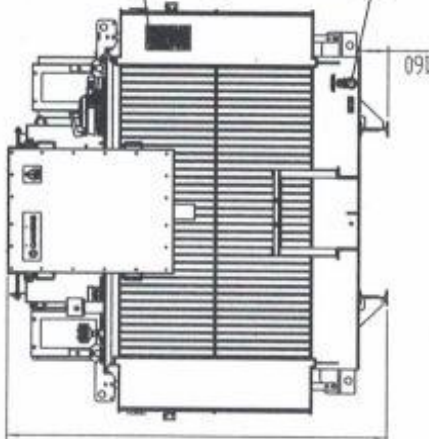
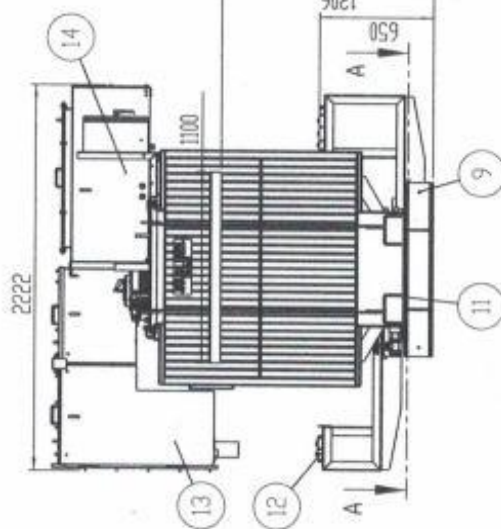

2394
2329
3X230

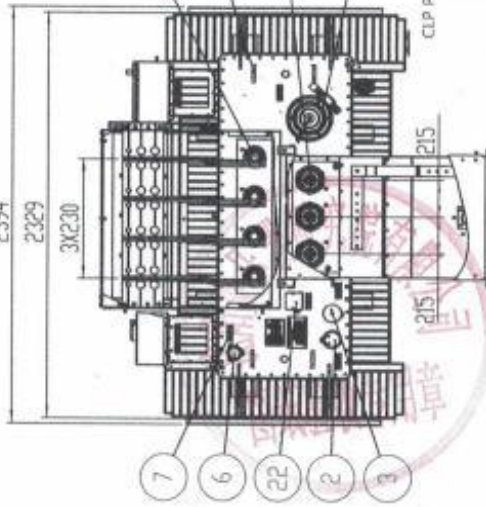

Section: A-A

支格

Oil Weight(kg)		Main Tank & others Weight(kg)	
22	Off Load Tap Changer	1490±10%	Core Weight(kg)
21	Sampling Valve	7790±5%	Copper Weight(kg)
20	LV Cable bracket	Adjustable by 100mm	1
19	Alarm terminal box	IP55	1
18	Auxiliary supply Fuse box	IP55 with lock and handle	1
17	Drain Valve	Gate valve	1
16	Fluid Plate	SS316L	2
15	Rating Plate	SS316L	1
14	LV Cable box	IPX2 with view window	1
13	HV Cable box	IP43	1
12	HV Cable Bracket	Adjustable by 100mm	1
11	Jacking Pad	125X125	4
10	Earthing Terminal	80x5x8 316L with tin	2
9	Base Support	1-Beams	2
8	Pressure relief Device	LPRJ	1
7	Label	SS316	8
6	DI Filling Dr-Drift	D60	1
5	LV bushing	Porcelain 1kV/3150A	4
4	LIFT-Lug	VLL 4tons/unit D40	4
3	DI Level indicator	Magnetic type	1
2	DI Temperature indicator	With contacts	1
1	HV bushing	36kV 630A TypeC EN50180	3
No.	Item	Description	QTY

CLP Power Hong Kong Limited

CATEGORY 'T'
APPROVED

Date: 18 December 2025
The signed data for release the liability of manufacturer / contractor is voiding construction and implementation of all data on this drawing / document
Signed by: [Signature]

- Note:
- (1) Other dimensions are subject to ±25mm tolerance;
 - (2) Major components and equipments will be labelled clearly;
 - (3) The shape and position of major components and equipments may be changed in production;
 - (4) The manufacturer of components may be changed to other qualified one;
 - (5) HV cable box is facilitated with earth copper bar or strap;
 - (6) Rating plate is fixed onto a cooling-fin cover with stainless steel rivet or bolt;
 - (7) transformer is equipped with 4 lift-lugs on cover that can lift the whole transformer without deformation;
 - (8) Alarm wiring through metallic is connected from pressure relief device, oil temperature indicator and oil level indicator to the alarm terminal box;
 - (9) M10 M4-70 bolt and nut is used to fix cover and tank together, between them there is O-ring to seal, which is compatible to ester oil;
 - (10) HV and LV cable box have appropriate space to hold the all the rated size cables;
 - (11) The pocket is located on the cover and is used to installed the oil temperature indicator;
 - (12) Painting color is RAL7033.



CONTRACTOR: Singapore Electrical Equipment Co., Ltd.
DRAWN: LY
DATE: 20/08/17
APPROVED: SJ
SCALE: 1:30
SHEET(S) IN SET: 1/20

NATURAL ESTER(FR3) IMMERSED
DISTRIBUTION TRANSFORMER
2000kVA 22.5/0.395kV KNAN
GENERAL LAYOUT

PROJECT NO: 70000817
CONTRACT NO: 70000817
DRG. NO: T/S00055491000C.H.R.001-1-S
INFORMATION CLASS: PROPRIETARY

CHPTL

中国大容量试验联盟(简称 CHPTL)是中国同类试验机构的唯一协作组织, 隶属于中国电工技术学会。

其主要目标是规范国家标准、行业标准及 IEC 标准在电力设备(交流 1000V 以上, 直流 1200V 以上)型式试验中的协调应用。

China High Power Testing liaison (CHPTL) is the only organization in China which is formed to promote and coordinate the application of IEC/GB standard as well as industry standards in power electrical equipment type test (AC above 1000V, DC above 1200V). CHPTL is under the leadership and management of China Electro-technical Society.

CHPTL 成员单位如下:

The members of CHPTL are as follows:

西安高压电器研究院有限责任公司(XIHARI)

Xi'an High Voltage Apparatus Research Institute Co., Ltd. (XIHARI)

中国电力科学研究院(CEPRI)

China Electrical Power Research Institute (CEPRI)

辽宁高压电器产品质量检测有限公司(AQTC)

Liaoning High Voltage Apparatus Quality Test Co., Ltd. (AQTC)

沈阳变压器研究院有限公司变压器实验室(STRI)

Shenyang Transformer Institute Co., Ltd Transformer Laboratory (STRI)

上海电气输配电试验中心有限公司(SETC)

Shanghai Electric Power Transmission & Distribution Testing Center Co., Ltd. (SETC)

电力工业无功补偿成套装置质量检验测试中心(PRCIQTC)

Power Industry Reactive Compensation Equipment Quality Inspection & Test Center(PRCIQTC)

CHPTL 作为一个协作组织, 本身并不出具型式试验报告。每一个 CHPTL 成员对其出具的型式试验报告的有效性和内容负责。

CHPTL as a collaboration does not itself issue test reports. Each CHPTL member issuing a test report is responsible for the validity and contents of that report.